



# DZCE\*K\*

## EXPLOSION-PROOF PRESSURE REDUCING VALVE WITH PROPORTIONAL CONTROL ATEX, IECEx, INMETRO SERIES 11

**DZCE5K\***      **CETOP P05**  
**DZCE5RK\***    **ISO 4401-05**  
**DZCE7K\***      **ISO 4401-07**  
**DZCE8K\***      **ISO 4401-08**

### OPERATING PRINCIPLE

- The DZCE\*K\* are explosion-proof pressure reducing valves, pilot operated, with proportional control, available with CETOP P05, ISO 4401-05, ISO 4401-07 and ISO 4401-08 mounting surfaces.
- They are compliant with ATEX, IECEx and INMETRO requirements and are suitable for use in potentially explosive atmospheres, for surface plants or mines.
- A low temperature version (up to -40 °C) is also available.
- They can be controlled directly by a current control supply unit or by means of an electronic card to exploit valve performance to the full (see par. 14).
- Upon request, DZCE\*K\* valves can be supplied with a finishing surface treatment (zinc-nickel) which is suitable to ensure a salt spray resistance up to 600 hours.
- **Details for classification, operating temperatures and electrical characteristics are in the technical data sheet 02 500 'Explosion proof classification'.**

<b>PERFORMANCES</b> (obtained with mineral oil with viscosity of 36 cSt at 50°C )		<b>DZCE5K*</b> <b>DZCE5RK*</b>	<b>DZCE7K*</b>	<b>DZCE8K*</b>
Maximum operating pressure	bar	350		
Maximum flow	l/min	150	300	500
Step response		see paragraph 4		
Hysteresis (with PWM 200 Hz)	% of p <sub>max</sub>	< 4%		
Repeatability	% of p <sub>max</sub>	< ±2%		
Electrical characteristic		see paragraph 7		
Temperature ranges (ambient and fluid)		see data sheet 02 500		
Fluid viscosity range	cSt	10 ÷ 400		
Fluid contamination degree	According to ISO 4406:1999 class 18/16/13			
Recommended viscosity	cSt	25		
Mass	kg	7,3	9,5	15,6

### HYDRAULIC SYMBOL

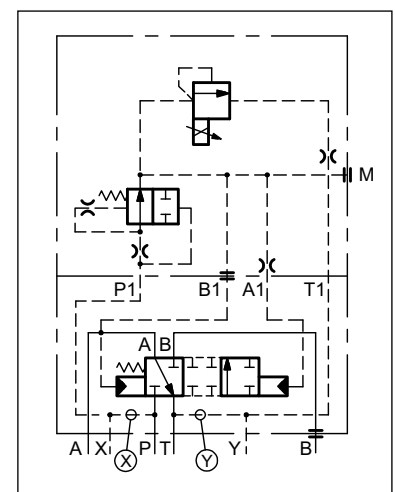



## 1 - IDENTIFICATION CODE

<b>D</b>	<b>Z</b>	<b>C</b>	<b>E</b>		<b>-</b>	<b>/ 11</b>		<b>-</b>		<b>/</b>	<b>K9</b>		
----------	----------	----------	----------	--	----------	-------------	--	----------	--	----------	-----------	--	--

Pressure reducing valve

Electric proportional control

Nominal size: \_\_\_\_\_  
**5** = CETOP P05  
**5R** = ISO 4401-05  
**7** = ISO 4401-07  
**8** = ISO 4401-08

Explosion-proof certification: \_\_\_\_\_  
**See table 1.1**

Pressure control range \_\_\_\_\_  
**070** = 1 ÷ 70 bar  
**140** = 1 ÷ 140 bar  
**210** = 1 ÷ 210 bar  
**300** = 1 ÷ 300 bar

Series N. (the overall and mounting dimensions remain unchanged from 10 to 19)

Seals: \_\_\_\_\_  
 For temperature range -20 / +80 °C  
**N** = NBR seals for mineral oil (**standard**)  
**V** = FPM seals for special fluids  
 For temperature range -40 / +80 °C  
**NL** = seal for low temperatures (for mineral oil)

Option: surface treatment not standard. Omit if not required (see **NOTE**)

Option: **/T5** version in T5 temperature class. Omit if not required.

Connection type for cable gland upper connection:  
**T01** = M20x1.5 - ISO 261  
**T02** = Gk 1/2 - UNI EN 10226-2 not available for INMETRO  
**T03** = 1/2" NPT - ANSI B1.20.1 (ex ANSI B2.1)  
 side connection:  
**S01** = M20x1.5 - ISO 261  
**S02** = Gk 1/2 - UNI EN 10226-2 not available for INMETRO  
**S03** = 1/2" NPT - ANSI B1.20.1 (ex ANSI B2.1)  
**S04** = M16x1.5 - ISO 261

Coil electrical connection: by terminal block

Nominal solenoid voltage:  
**D12** = 12V DC  
**D24** = 24V DC

Drainage: **I** = internal  
**E** = external

Piloting: **I** = internal  
**E** = external

**NOTE:** the valves are supplied with standard surface treatment of phosphating black.  
 Upon request we can supply these valves with full zinc-nickel surface treatment, suitable to ensure a salt spray resistance up to 600 h (test operated according to UNI EN ISO 9227 standards and test evaluation operated according to UNI EN ISO 10289 standard).  
 For zinc-nickel surface treatment add **/W7** at the end of the identification code.

### 1.1 - Names of valves per certification

	ATEX		IECEX		INMETRO	
for gases for dusts	<b>KD2</b>	II 2GD	<b>KXD2</b>	IECEX Gb IECEX Db	<b>KBD2</b>	INMETRO Gb INMETRO Db
for mines	<b>KDM2</b>	I M2	<b>KXDM2</b>	IECEX Mb	<b>KBDM2</b>	INMETRO Mb

**NOTE:** Refer to the technical data sheet 02 500 for marking, operating temperatures and available versions.



## 2 - CHARACTERISTIC CURVES

(obtained with mineral oil with viscosity of 36 cSt at 50°C)

### 2.1 - Characteristic curves DZCE5K\* and DZCE5RK\*

ADJUSTMENT

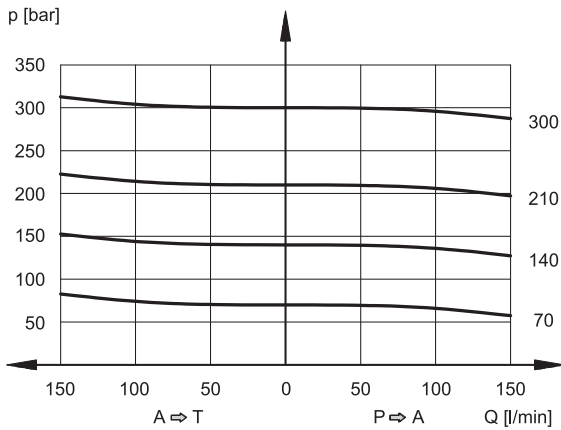

MIN. CONTROLLED PRESSURE  $p_{min} = f(Q)$

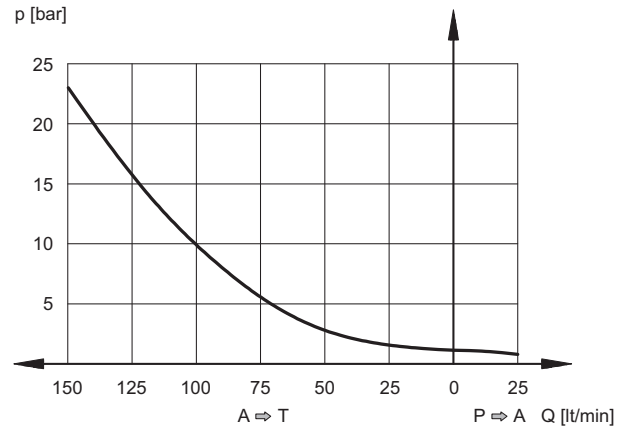

### 2.2 - Characteristic curves DZCE7K\*

ADJUSTMENT

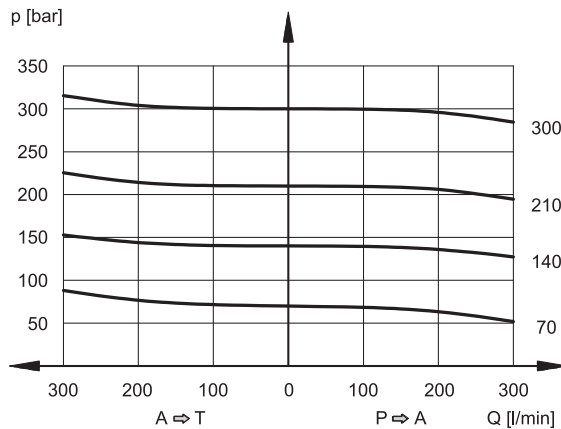

MIN. CONTROLLED PRESSURE  $p_{min} = f(Q)$

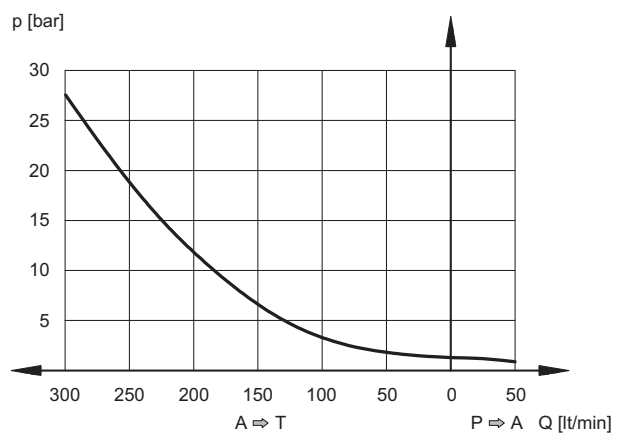

### 2.3 - Characteristic curves DZCE8K\*

ADJUSTMENT

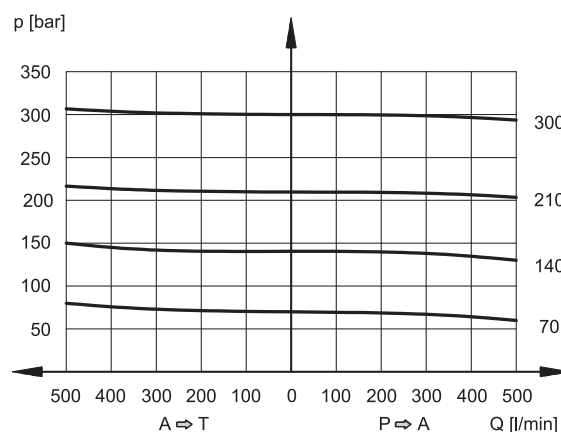

MIN. CONTROLLED PRESSURE  $p_{min} = f(Q)$

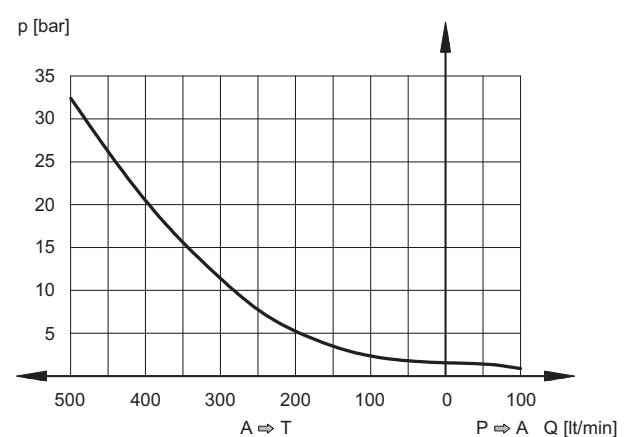



### 2.4 - Pressure control $p = f(I)$ DZCE5K\*, DZCE5RK\*, DZCE7K\* and DZCE8K\*

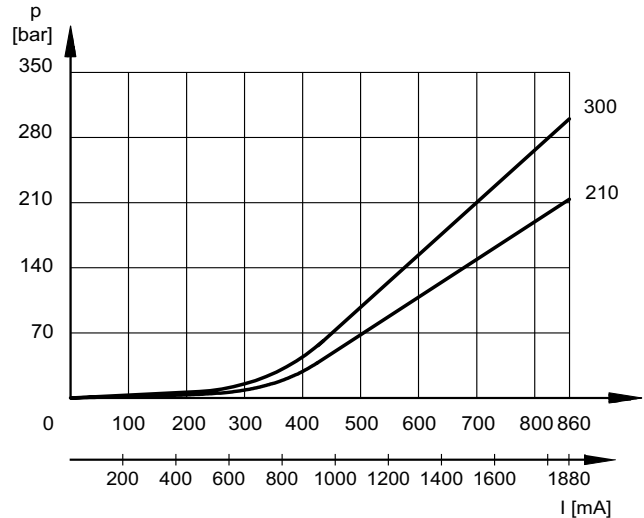
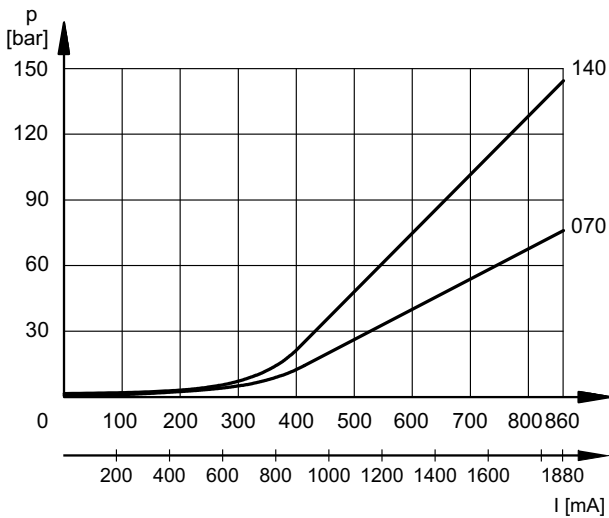

### 3 - STEP RESPONSE

(measured with mineral oil with viscosity of 36 cSt at 50°C)

Step response is the time taken for the valve to reach 90% of the set pressure value following a step change of reference signal.

REFERENCE SIGNAL STEP	0 → 100%	100 → 0%
Response times [ms]		
<b>DZCE5K* and DZCE5RK*</b>	100	70
<b>DZCE7K*</b>	100	50
<b>DZCE8K*</b>	100	50

### 4 - ELECTRICAL CHARACTERISTICS

(values ± 5%)

NOMINAL VOLTAGE	V DC	12	24
RESISTANCE (AT 20°C)	Ω	3,4	15,6
NOMINAL CURRENT	A	1,88	0,86

<b>DUTY CYCLE</b>	100%
<b>ELECTROMAGNETIC COMPATIBILITY (EMC)</b>	According to 2014/30/EU
<b>CLASS OF PROTECTION:</b> Atmospheric agents Coil insulation (VDE 0580)	IP66 / IP68 class H

#### 4.1 - Wiring

In order to realise the electrical connection of the coil, it is necessary to access the terminal block (1) unscrewing the 4 screws (2) that fasten the cover (3) with the box (4) that contains the terminal block.

**The electrical connection is polarity-independent.**

By doing electrical connection it is important to connect also the grounding point (5) in the terminal block box (M4 screws), through suitable conductors with the general grounding line of the system.

On the external body of the coil there is a grounding point (6) (M4 screw) that allow to ensure equipotentiality between the valve and the general grounding line of the system; connecting this point the regulation of the EN 13463-1 standard, that impose to verify the equipotentiality of the elements included in a potentially explosive environment (the maximum resistance between the elements must be 100 Ω), is guaranteed.

At the end of the electrical wiring, it is necessary to reassemble the cover (3) on the box (4), checking the correct positioning of the seal located in the cover seat and fastening the 4 M5 screws with a torque of 4.9+6 Nm.

Electrical wiring must be done following in compliance with standards about protection against explosion hazards.

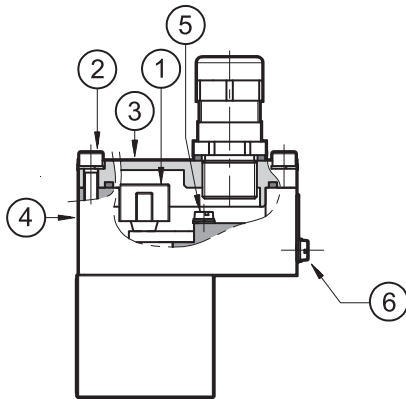

K9T\*

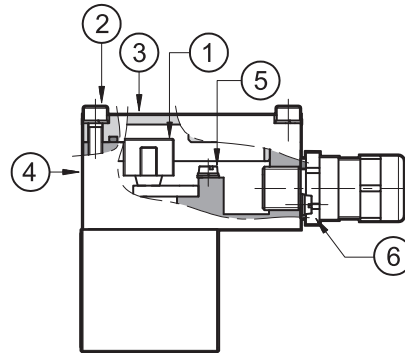

K9S\*

Characteristics of the cables connectable for wiring are indicated in the table below:

Function	Cable section
Operating voltage cables connection	max 2.5 mm <sup>2</sup>
Connection for internal grounding point	max 2.5 mm <sup>2</sup>
Connection for external equipotential grounding point	max 6 mm <sup>2</sup>

Cables for wiring must be non-armoured cables, with external covering sheath and must be suitable for use in environments with temperatures from - 20 °C to +110 °C (for valves either with N or V seals) or from - 40 °C to +110 °C (for valves with NL seals).

Cable glands (which must be ordered separately, see paragraph 14) allow to use cables with external diameter between 8 and 10 mm.

#### 4.2 - Electrical diagram

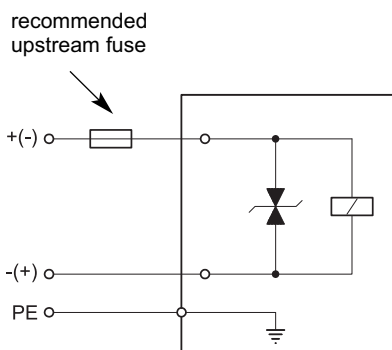

#### 4.3 - Overcurrent fuse and switch-off voltage peak

Upstream of each valve, an appropriate fuse (max 3 x I<sub>n</sub> according to IEC 60127) or a protective motor switch with short-circuit and thermal instantaneous tripping, as short-circuit protection, must be connected. The cut-off power of the fuse must correspond or exceed the short circuit current of the supply source. The fuse or the protective motor must be placed outside the dangerous area or they must be protected with an explosion-proof covering.

In order to safeguard the electronic device to which the valve is connected, there is a protection circuit in the coil, that reduces voltage peaks, which can occur when inductances are switched off.

The table shows the type of fuse recommended according to the nominal voltage of the valve and to the value of the voltage peaks reduction.

Coil type	Nominal voltage [V]	Rated current [A]	Recommended pre-fuse characteristics medium time-lag according to DIN 41571 [A]	Maximum voltage value upon switch off [V]	Suppressor circuit
D12	12	1,88	2,5	- 49	Transient voltage suppressor bidirectional
D24	24	0,86	1,25	- 49	

## 5 - PILOT AND DRAIN

The DZCE\*K\* valves are available with piloting and drainage, both internal and external.  
We suggest to use the version with external drainage that allows a higher backpressure on the unloading.

TYPE OF VALVE	Plug assembly	
	X	Y
<b>IE</b> INTERNAL PILOT AND EXTERNAL DRAIN	NO	YES
<b>II</b> INTERNAL PILOT AND INTERNAL DRAIN	NO	NO
<b>EE</b> EXTERNAL PILOT AND EXTERNAL DRAIN	YES	YES
<b>EI</b> EXTERNAL PILOT AND INTERNAL DRAIN	YES	NO

**DZCE5K\* and DZCE5RK\***

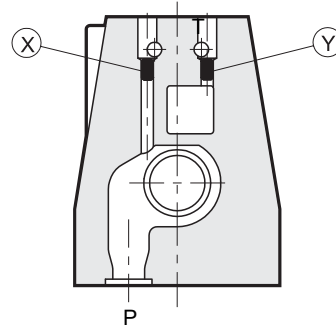

**X:** M5x6 plug for external pilot  
**Y:** M5x6 plug for external drain

PRESSURES [bar]	MIN	MAX
Piloting pressure on X port	30	350
Pressure in T port with internal drain	-	2
Pressure in T port with external drain	-	250

**DZCE7K\***

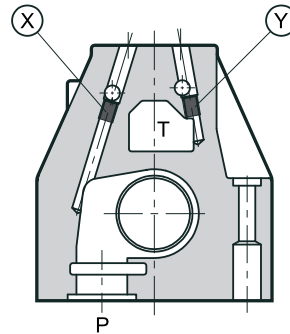

**X:** M6x8 plug for external pilot  
**Y:** M6x8 plug for external drain

**DZCE8K\***

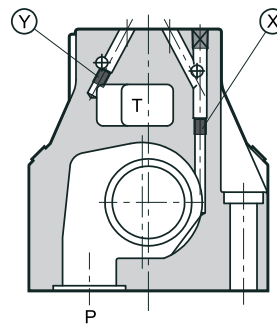

**X:** M6x8 plug for external pilot  
**Y:** M6x8 plug for external drain

## 6 - DZCE5K\* AND DZCE5RK\* OVERALL AND MOUNTING DIMENSIONS

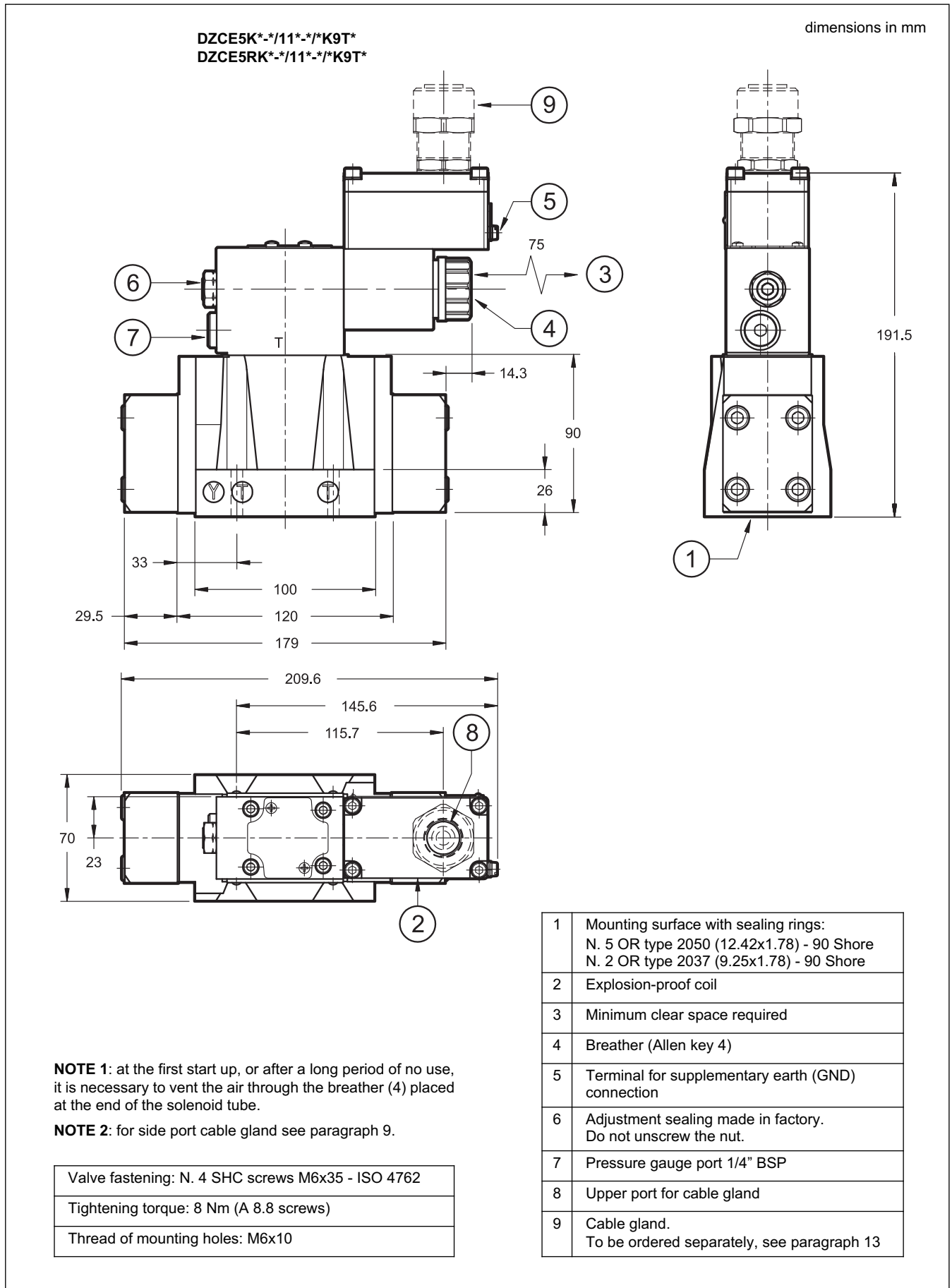

## 7 - DZCE7K\* OVERALL AND MOUNTING DIMENSIONS

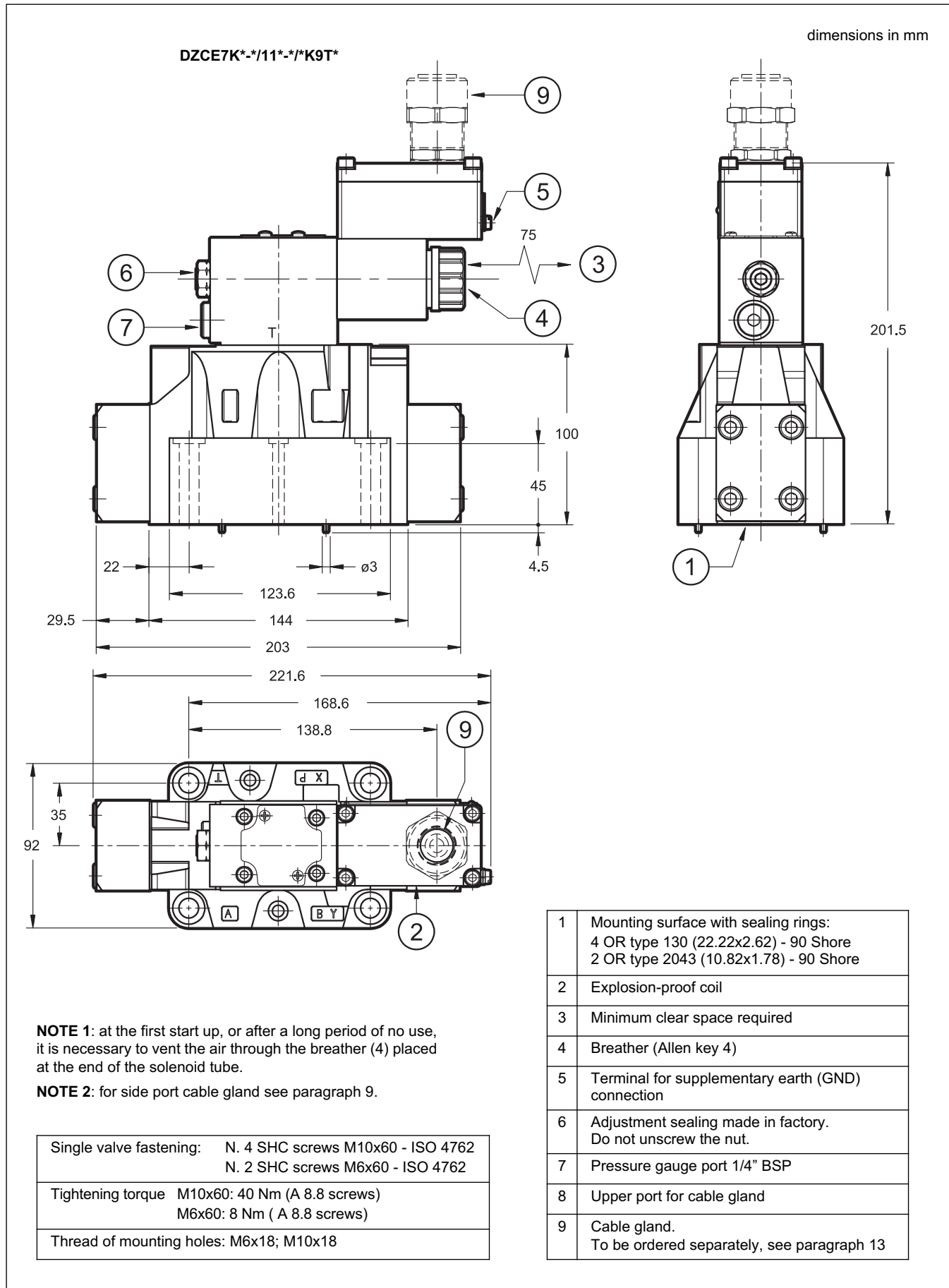



## 8 - DZCE8K\* OVERALL AND MOUNTING DIMENSIONS

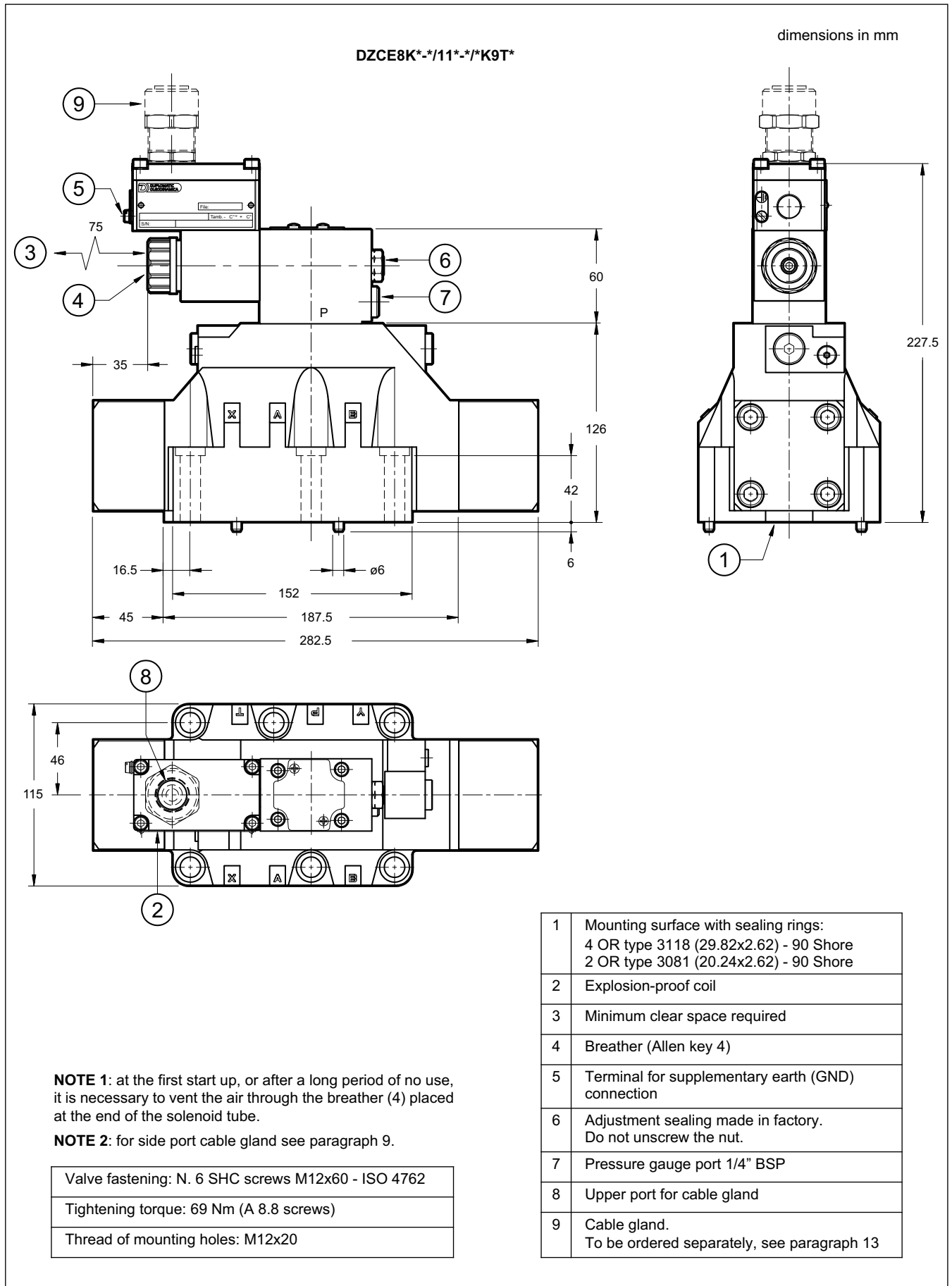

## 9 - DZCE\*K\* WITH SIDE CONNECTION OVERALL AND MOUNTING DIMENSIONS

dimensions in mm

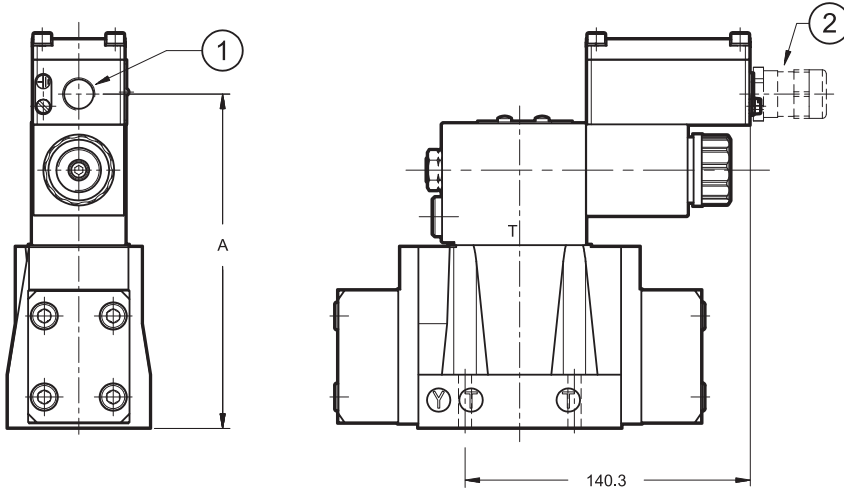

**DZCE5K\*-/11\*-/K9S\***  
**DZCE5RK\*-/11\*-/K9S\***

Side port type	Dimension A
<b>S01, S04</b>	180.5
<b>S02, S03</b>	180

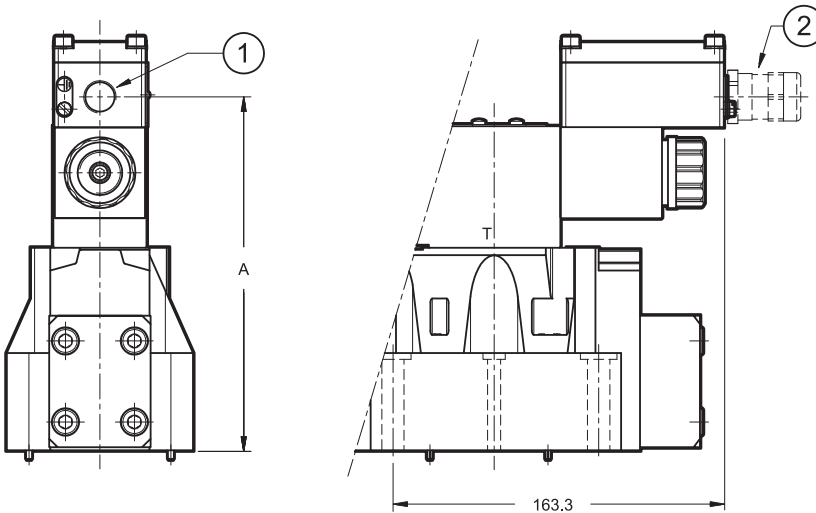

**DZCE7K\*-/11\*-/K9S\***

Side port type	Dimension A
<b>S01, S04</b>	190.5
<b>S02, S03</b>	190

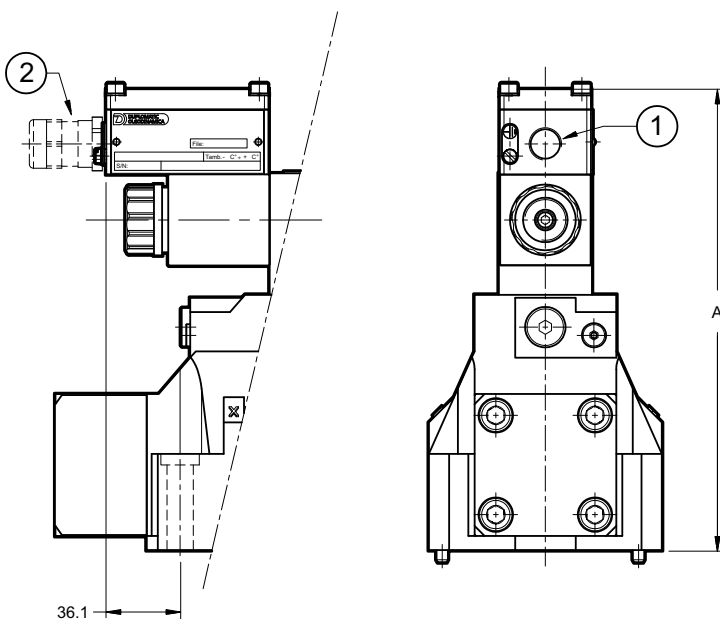

**DZCE8K\*-/11\*-/K9S\***

Side port type	Dimension A
<b>S01, S04</b>	226.5
<b>S02, S03</b>	226

1	Side port for cable gland
2	Cable gland. To be ordered separately, see par. 13



## 10 - MOUNTING SURFACES

### DZCE5RK\*

ISO 4401-05-05-0-05  
(CETOP 4.2-4 R05-350)

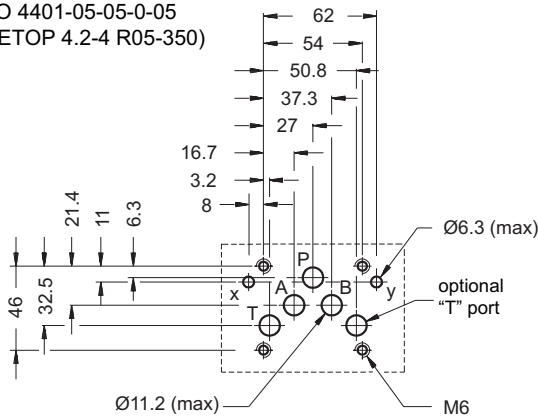

### DZCE5K\*

CETOP 4.2-4 P05-350

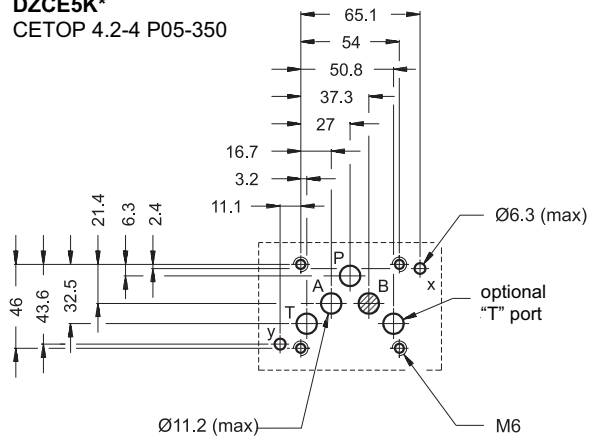

### DZCE7K\*

ISO 4401-07-07-0-05  
(CETOP 4.2-4-07-350)

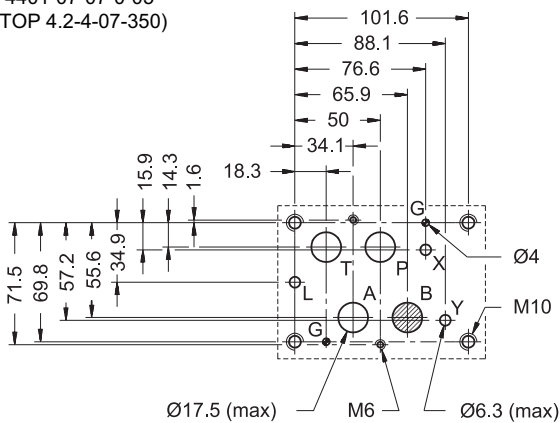

### DZCE8K\*

ISO 4401-08-08-0-05  
(CETOP 4.2-4-08-350)

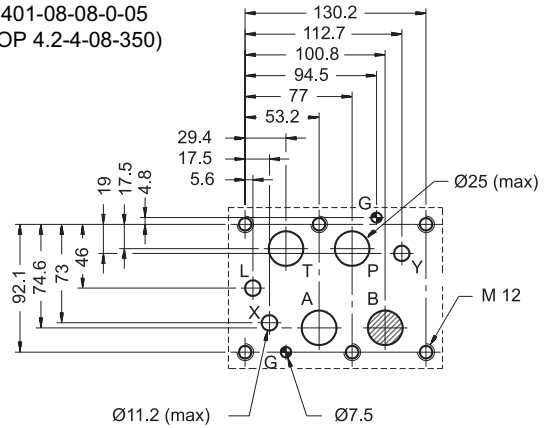

## 11 - HYDRAULIC FLUIDS

Use mineral oil-based hydraulic fluids HL or HM type, according to ISO 6743-4. For these fluids, use NBR seals (code N). For fluids HFDR type (phosphate esters) use FPM seals (code V). For the use of other kinds of fluid such as HFA, HFB, HFC, please consult our technical department. Using fluids at temperatures higher than 80 °C causes a faster degradation of the fluid and of the seals characteristics.

The fluid must be preserved in its physical and chemical characteristics.

## 12 - INSTALLATION



**Installation must adhere to instructions reported in the Use and Maintenance manual, always attached to the valve. Unauthorized interventions can be harmful to people and goods because of the explosion hazards present in potentially explosive atmospheres.**

We recommend to install the DZCE\*K\* valve either in horizontal position, or vertical position with the solenoid downward. If the valve is installed in vertical position and with the solenoid upward, you must consider possible variations of the minimum controlled pressure, if compared to what is indicated in paragraph 2.

Ensure that there is no air in the hydraulic circuit. In particular applications, it can be necessary to vent the air entrapped in the solenoid tube, using the special drain screw and then ensure to screw it correctly.

Connect the valve T port directly to the tank. Add any backpressure value detected in the T line to the controlled pressure value.

**Maximum admissible backpressure in the T line, under operational conditions, is 2 bar.**

Valves are fixed by means of screws or tie rods on a flat surface with planarity and roughness equal to or better than those indicated in the relative symbols. If minimum values are not observed, fluid can easily leak between the valve and support surface.

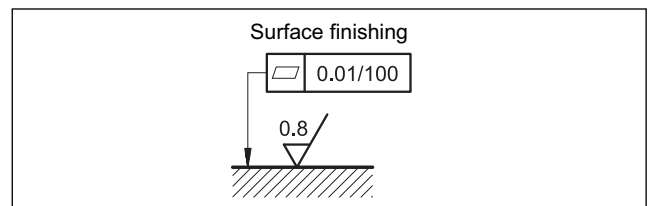



### 13 - CABLE GLANDS

Cable glands must be ordered separately; Diplomatic offers some types of cable glands with the following features:

- version for non-armoured cable, external seal on the cable (suitable for Ø8+10 mm cables);
- ATEX II 2GD, I M2; IECEx Gb, Db, Mb; INMETRO Gb, Db, Mb certified
- cable gland material: nickel brass
- rubber tip material: silicone
- ambient temperature range: -70 °C + +220 °C
- protection degree: IP66/IP68

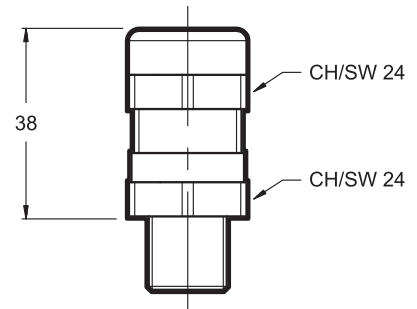

To order the desired cable glands, specify description, code and quantity.

**Description: CGK2/NB-01/10**

**Code: 3908108001**

M20x1.5 - ISO 261 male thread, suitable for coils with T01 and S01 connections. It is supplied equipped with copper washer, that must be assembled between the cable gland and the coil, so as to ensure IP66/IP68 protection degree.

Tightening torque: 45 ÷ 50 Nm

**Description: CGK2/NB-03/10**

**Code: 3908108003**

1/2" NPT - ANSI B1.20.1 (ex ANSI B2.1), suitable for coils with T03 and S03 connections. The customer must apply LOCTITE® 243™ threadlocker or similar between the cable gland connection thread and the coil in order to ensure IP66/IP68 protection degree.

Tightening torque: 20 ÷ 25 Nm

**Description: CGK2/NB-02/10**

**Code: 3908108002**

Gk 1/2 - UNI EN 10226-2 male thread, suitable for coils with T02 and S02 connections. The customer must apply LOCTITE® 243™ threadlocker or similar between the cable gland connection thread and the coil in order to ensure IP66/IP68 protection degree.

Tightening torque: 20 ÷ 25 Nm

**Description: CGK2/NB-04/10**

**Code: 3908108004**

M16x1.5 - ISO 261 male thread, suitable for coils with S04 connection. It is supplied equipped with copper washer, that must be assembled between the cable gland and the coil, so as to ensure IP66/IP68 protection degree.

Tightening torque: 45 ÷ 50 Nm

### 14 - ELECTRONIC CONTROL UNITS

<b>EDM-M112</b>	for solenoid 24V DC	DIN EN 50022 rail mounting	see cat. 89 250
<b>EDM-M142</b>	for solenoid 12V DC		

**NOTE: electronic control units offered are not explosion-proof certified; therefore, they must be installed outside classified areas.**

### 15 - SUBPLATES

(see catalogue 51 000)

	DZCE5K*	DZCE7K*	DZCE8K*
Type with rear ports	PME4-AI5G	PME07-AI6G	-
Type with side ports	PME4-AL5G	PME07-AL6G	PME5-AL8G
Thread of ports:	P - T - A - B X - Y	3/4" BSP 1/4" BSP	1 1/2" BSP 1/4" BSP

**NOTE:** Subplates (to be ordered separately) do not contain neither aluminium nor magnesium at a rate higher than the value allowed by norms according to ATEX directive for category II 2GD and I M2.

The user will bear to do the complete assessment of the ignition risk that can occur from the relative use in potentially explosive environments.



**DIPLOMATICO OLEODINAMICA S.p.A.**  
 20015 PARABIAGO (MI) • Via M. Re Depaolini 24  
 Tel. +39 0331.895.111  
 Fax +39 0331.895.339  
 www.diplomatic.com • e-mail: sales.exp@diplomatic.com



# EXPLOSION-PROOF CLASSIFICATION

## for

### SOLENOID AND PROPORTIONAL VALVES

ref. catalogues:

pressure valves

<b>RQM*K*-P</b>	<b>21 515</b>
<b>PRE(D)*K*</b>	<b>81 315</b>
<b>ZDE3K*</b>	<b>81 515</b>
<b>DZCE*K*</b>	<b>81 605</b>

directional valves

<b>D*K*</b>	<b>41 515</b>
<b>DS(P)E*K*</b>	<b>83 510</b>

#### GENERAL INFO

This informative technical datasheet displays information about **classification and marking** of Duplomatic explosion-proof valves range.

Duplomatic offers valves with the following certifications:

<b>ATEX</b>	<b>II 2G</b>	<b>II 2D</b>	<b>I M2</b>
<b>IECEX</b>	<b>Gb</b>	<b>Db</b>	<b>Mb</b>
<b>INMETRO</b>	<b>Gb</b>	<b>Db</b>	<b>Mb</b>

Instructions for use and maintenance can be found in the related manuals, always supplied together with valves.



## 1 - ATEX CLASSIFICATION AND TEMPERATURES

Diplomatic certificates the combination valve-coil for the valves suitable for application and installation in potentially explosive atmospheres, according to ATEX directive; the supply always includes the declaration of conformity to the directive and the operating and maintenance manual, that contains all the information needed for a correct use of the valve in potentially explosive environments.

Coils assembled on these valves have been separately certified according to ATEX directive and so they are suitable for use in potentially explosive atmospheres.

### 1.1 - ATEX classification for valves

Type examination certificate: CEC 13 ATEX 030-REV.2

The valves are suitable for applications and installations in potentially explosive atmospheres that fall within:

ATEX II 2G ATEX II 2D	<b>*KD2</b>	equipment intended for use in areas in which explosive atmospheres caused by gases, vapours, mists or air/dust mixtures are likely to occur occasionally.
ATEX I M2	<b>*KDM2</b>	equipment intended for use in underground parts of mines as well as those parts of surface installations of such mines likely to be endangered by firedamp and/or combustible dust. This equipment is intended to be de-energised in the event of an explosive atmosphere.

### 1.2 - ATEX marking for valves

valve code		N and V seals	NL seals
<b>*KD2</b>	for gas	II 2G IIC T4 Gb (-20°C Ta +80°C)	II 2G IIC T4 Gb (-40°C Ta +80°C)
	for dusts	II 2D IIIC T154°C Db IP66/IP68 (-20°C Ta +80°C)	II 2D IIIC T154°C Db IP66/IP68 (-40°C Ta +80°C)
<b>*KD2 /T5</b>	for gas	II 2G IIC T5 Gb (-20°C Ta +55°C)	II 2G IIC T5 Gb (-40°C Ta +55°C)
	for dusts	II 2D IIIC T129°C Db IP66/IP68 (-20°C Ta +55°C)	II 2D IIIC T129°C Db IP66/IP68 (-40°C Ta +55°C)
<b>*KDM2</b>	mining	I M2 I T150°C Mb IP66/68 (-20°C Ta +75°C)	I M2 I T150°C Mb IP66/68 (-40°C Ta +75°C)

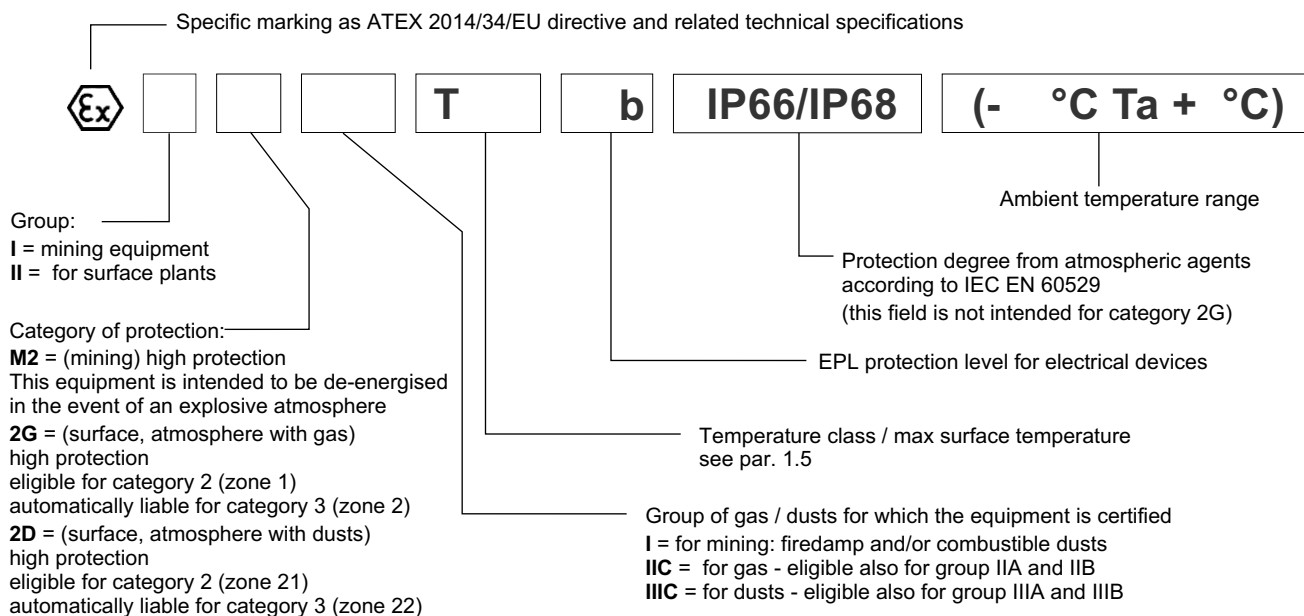



### 1.3 - ATEX classification of the coils

The coil of the explosion-proof valves is ATEX certified itself as such is identified with its own tag, carries the relative ATEX marking. The mechanical construction of the coil housing is made in order to ensure its resistance to possible internal explosion and to avoid any explosion propagation to the outside environment, matching an "Ex d" type protection (explosion-proof coil).

Moreover, the solenoid is designed to maintain its surface temperature below the limits specified to the relevant class.

### 1.4 - ATEX marking on coils

for valve type <b>*KD2</b>	for gas for dusts	II 2G Ex d IIC T4 Gb (-40°C Ta +80°C) II 2D Ex tb IIIC T154°C Db IP66/IP68 (-40°C Ta +80°C)
for valve type <b>*KD2 /T5</b>	for gas for dusts	II 2G Ex d IIC T5 Gb (-40°C Ta +55°C) II 2D Ex tb IIIC T129°C Db IP66/IP68 (-40°C Ta +55°C)
for valve type <b>*KDM2</b>	mining	I M2 Ex d I T150°C Mb IP66/IP68 (-40°C Ta +75°C)

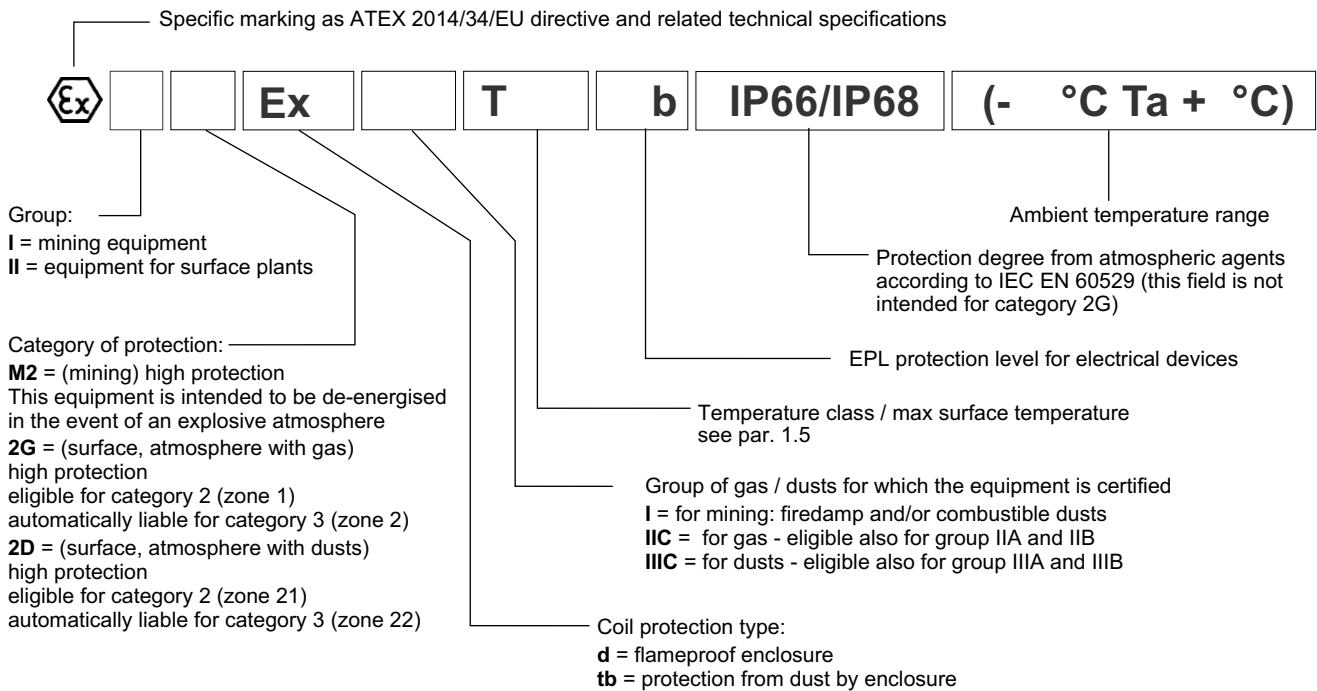

### 1.5 - Operating temperatures

These valves are classified according to their maximum surface temperature (EN 13463-1), which must be lower than the ignition temperature of the gases, vapors and dusts for which the area in which they will be used is classified.

The valves in group II can also be used for less limiting temperature classes (surface temperature allowed higher).

		temperature range	N and V seals	NL seals	Temperature class	eligible also for
ATEX II 2G ATEX II 2D	<b>*KD2</b>	of ambient	-20 / +80 °C	-40 / +80 °C	T4 (gas) T154°C (dusts)	T3, T2, T1 T200°C and higher
		of fluid				
	<b>*KD2 /T5</b>	of ambient	-20 / +55 °C	-40 / +55 °C	T5 (gas) T129°C (dusts)	T4, T3, T2, T1 T135°C and higher
		of fluid				
ATEX I M2	<b>*KDM2</b>	of ambient	-20 / +75 °C	-40 / +75 °C	T150°C	-
		of fluid				



## 2 - IECEx CLASSIFICATION AND TEMPERATURES

The IECEx certification requires the classification of the electrical equipment only.

Diplomatic supplies valves with IECEx certified coils, suitable for application and installation in potentially explosive atmospheres. The mechanical construction of the coil housing is made in order to ensure its resistance to possible internal explosion and to avoid any explosion propagation to the outside environment, matching an "Ex db" type protection (explosion-proof coil).

Moreover, the solenoid is designed to maintain its surface temperature below the limits specified to the relevant class.

The supply always includes the operating and maintenance manual, that contains all the information needed for a correct use of the valve in potentially explosive environment.

### 2.1 - IECEx classification

Certificate of conformity (CoC): IECEx TUN 15.0028X

The valves are suitable for applications and installations in potentially explosive atmospheres that fall within:

IECEx Gb IECEx Db	<b>*KXD2</b>	equipment intended for use in areas in which explosive atmospheres caused by gases, vapours, mists or air/dust mixtures are likely to occur occasionally.
IECEx Mb	<b>*KXDM2</b>	equipment intended for use in underground parts of mines as well as those parts of surface installations of such mines likely to be endangered by firedamp and/or combustible dust. This equipment is intended to be de-energised in the event of an explosive atmosphere.

### 2.2 - IECEx marking

There is a plate with the IECEx mark on each coil.

<b>*KXD2</b> valves	for gas	Ex db IIC T4 Gb (-40°C Ta +80°C)
	for dusts	Ex tb IIIC T135°C Db (-40°C Ta +80°C)
<b>*KXD2 /T5</b> valves	for gas	Ex db IIC T5 Gb (-40°C Ta +55°C)
	for dusts	Ex tb IIIC T100°C Db (-40°C Ta +55°C)
<b>*KDM2</b> valves	mining	Ex db I Mb (-40°C Ta +80°C)

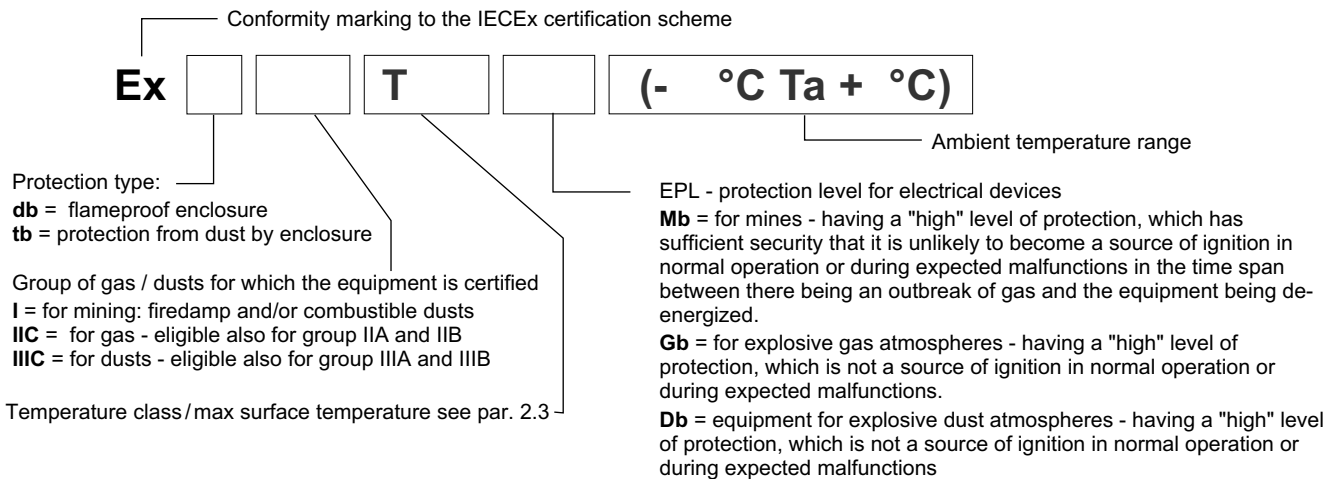

### 2.3 - Operating temperatures

These valves are classified according to their maximum surface temperature (EN 13463-1), which must be lower than the ignition temperature of the gases, vapors and dusts for which the area in which they will be used is classified.

Valves for surface plants can also be used for less limiting temperature classes (higher surface temperature allowed).

		temperature range	N and V seals	NL seals	Temperature class	eligible also for
IECEx Gb IECEx Db	<b>*KXD2</b>	of ambient	-20 / +80 °C	-40 / +80 °C	T4 (gas) T135°C (dusts)	T3, T2, T1 T200°C and higher
		of fluid				
IECEx Gb IECEx Db	<b>*KXD2 /T5</b>	of ambient	-20 / +55 °C	-40 / +55 °C	T5 (gas) T100°C (dusts)	T4, T3, T2, T1 T135°C and higher
		of fluid				
IECEx Mb	<b>*KXDM2</b>	of ambient	-20 / +80 °C	-40 / +80 °C	-	-
		of fluid				





### 3 - INMETRO CLASSIFICATION AND TEMPERATURES

The INMETRO certification requires the classification of the electrical equipment only.

Diplomatic supplies valves with INMETRO certified coils, suitable for application and installation in potentially explosive atmospheres. The mechanical construction of the coil housing is made in order to ensure its resistance to possible internal explosion and to avoid any explosion propagation to the outside environment, matching an "Ex d" type protection (explosion-proof coil).

Moreover, the solenoid is designed to maintain its surface temperature below the limits specified to the relevant class.

The supply always includes the operating and maintenance manual, that contains all the information needed for a correct use of the valve in potentially explosive environment.

#### 3.1 - INMETRO classification

Certificate of conformity: DNV 15.0094 X

The valves are suitable for applications and installations in potentially explosive atmospheres that fall within:

INMETRO Gb INMETRO Db	<b>*KBD2</b>	equipment intended for use in areas in which explosive atmospheres caused by gases, vapours, mists or air/dust mixtures are likely to occur occasionally.
INMETRO Mb	<b>*KBDM2</b>	equipment intended for use in underground parts of mines as well as those parts of surface installations of such mines likely to be endangered by firedamp and/or combustible dust. This equipment is intended to be de-energised in the event of an explosive atmosphere.

#### 3.2 - INMETRO marking

There is a plate with the INMETRO mark on each coil.

<b>*KBD2</b> valves	for gas	Ex d IIC T4 Gb (-40°C Ta +80°C)
	for dusts	Ex tb IIIC T154°C Db IP66/IP68 (-40°C Ta +80°C)
<b>*KBD2 /T5</b> valves	for gas	Ex d IIC T5 Gb (-40°C Ta +55°C)
	for dusts	Ex tb IIIC T129°C Db IP66/IP68 (-40°C Ta +55°C)
<b>*KBDM2</b> valves	mining	Ex d I T150° Mb IP66/IP68 (-40°C Ta +75°C)

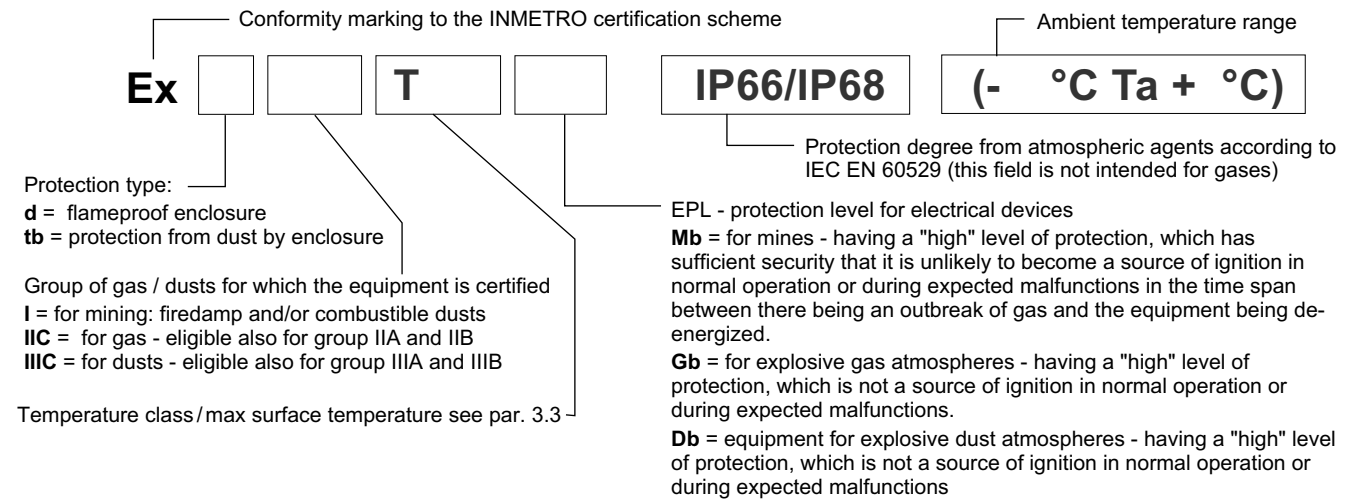

#### 3.3 - Operating temperatures

These valves are classified according to their maximum surface temperature (EN 13463-1), which must be lower than the ignition temperature of the gases, vapors and dusts for which the area in which they will be used is classified.

Valves for surface plants can also be used for less limiting temperature classes (higher surface temperature allowed).

		temperature range	N and V seals	NL seals	Temperature class	eligible also for
INMETRO Gb INMETRO Db	<b>*KBD2</b>	of ambient	-20 / +80 °C	-40 / +80 °C	T4 (gas) T154°C (dusts)	T3, T2, T1 T200°C and higher
		of fluid				
INMETRO Db	<b>*KBD2 /T5</b>	of ambient	-20 / +55 °C	-40 / +55 °C	T5 (gas) T129°C (dusts)	T4, T3, T2, T1 T135°C and higher
		of fluid				
INMETRO Mb	<b>*KBDM2</b>	of ambient	-20 / +75 °C	-40 / +75 °C	T150°C	-
		of fluid				



**DIPLOMATIC OLEODINAMICA S.p.A.**  
20015 PARABIAGO (MI) • Via M. Re Depaolini 24  
Tel. +39 0331.895.111  
Fax +39 0331.895.339  
[www.diplomatic.com](http://www.diplomatic.com) • e-mail: [sales.exp@diplomatic.com](mailto:sales.exp@diplomatic.com)

