

DL3

SOLENOID OPERATED DIRECTIONAL CONTROL VALVE COMPACT VERSION

SUBPLATE MOUNTING
ISO 4401-03 (CETOP 03)

p max **280** bar
Q max **50** l/min

MOUNTING INTERFACE

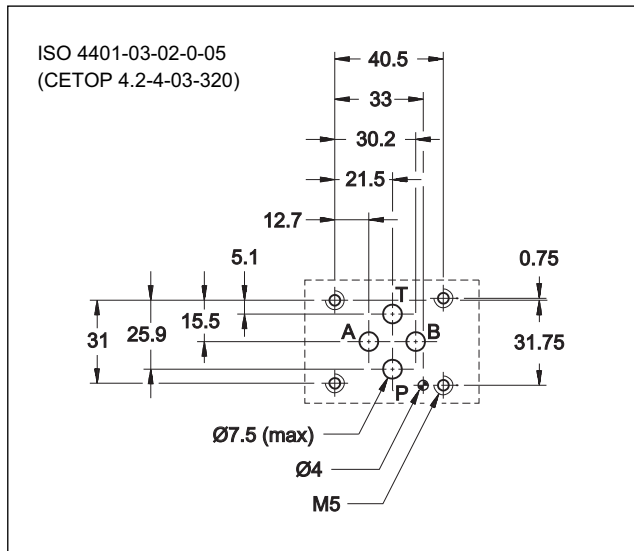

OPERATING PRINCIPLE

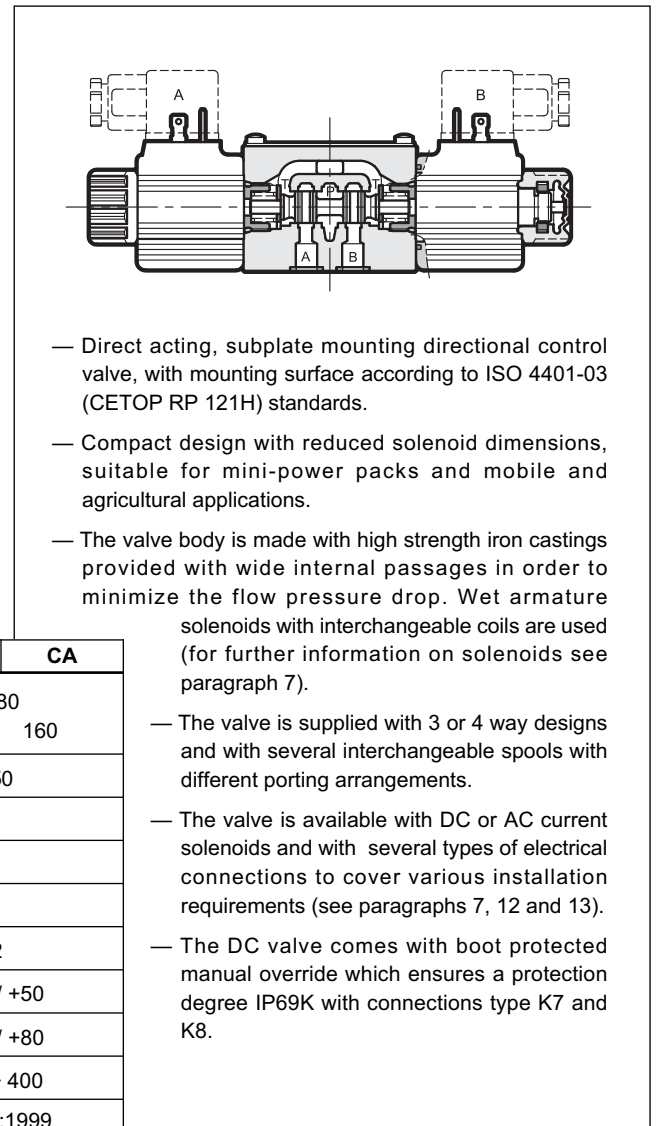

PERFORMANCES (with mineral oil of viscosity of 36 cSt at 50°C)

	bar	CC	CA
		280	160
Maximum operating pressure: - ports P - A - B - port T		250	
Maximum flow rate	l/min	50	
Pressure drop Δp -Q		see paragraph 4	
Operating limits		see paragraph 5	
Electrical features		see paragraph 7	
Electrical connections		see paragraph 12	
Ambient temperature range	°C	-20 / +50	
Fluid temperature range	°C	-20 / +80	
Fluid viscosity range	cSt	10 ÷ 400	
Fluid contamination degree		according to ISO 4406:1999 class 20/18/15	
Recommended viscosity	cSt	25	
Masse: single solenoid valve double solenoid valve	kg	1,1 1,4	

1 - IDENTIFICATION CODE

D	L	3	-	/		-		/	
----------	----------	----------	----------	----------	--	----------	--	----------	--

Solenoid operated directional control valve

Compact version

ISO 4401-03 (CETOP 03) size

Spool type (see paragraph 3):

S*	TA
SA*	TB
SB*	RK

Series no.:

10 = for direct current valves
11 = for alternate current valves
(the overall and mounting dimensions remain unchanged from 10 to 19)

Seals:

N = NBR seals for mineral oil (**standard**)
V = FPM seals for special fluids

NOTE 1: Coils locking ring and related OR are supplied together with valves.

NOTE 2: The valve is supplied with standard surface treatment of phosphating black. On request we can supply these valves with other surface finishes. Add suffix **/ W *** at the end of the code.

W2 = mat epoxy painting black RAL 9005
thickness 20 ± 40µ

W4 = gas nitriding and oxidation process black colour

Option: Surface treatment not standard. Omit if not required (see **NOTE 2**)

Manual override (see par. 11)
on **DC** version:
omit for override integrated in the coil locking ring
CK = knob
on **AC** version:
omit for override integrated in the tube
CM = boot protected

Coil electrical connection: (see paragraph 12)

DC supply

K1 = plug for connector type DIN 43650 (**standard**)

K2 = plug for connector type AMP JUNIOR

K4 = outgoing cables

K7 = plug DEUTSCH DT04-2P for male connector type DEUTSCH DT06-2S

K8 = plug for connector type AMP SUPER SEAL

AC supply

K1 = plug for connector type DIN 43650 (**standard**)

DC power supply

D12 = 12 V	}	direct current
D24 = 24 V		
D28 = 28 V		
D48 = 48 V		
R110 = 110 V	}	rectified current
R230 = 230 V		

D00 = valve without coils (see **NOTE 1**)

AC power supply

A24 = 24 V - 50 Hz
A48 = 48 V - 50 Hz
A110 = 110 V - 50 Hz
A230 = 230 V - 50 Hz

A00 = valve without coils (see **NOTE 1**)

2 - HYDRAULIC FLUIDS

Use mineral oil-based hydraulic fluids HL or HM type, according to ISO 6743-4. For these fluids, use NBR seals (code N). For fluids HFDR type (phosphate esters) use FPM seals (code V). For the use of other fluid types such as HFA, HFB, HFC, please consult our technical department. Using fluids at temperatures higher than 80 °C causes a faster degradation of the fluid and of the seals characteristics. The fluid must be preserved in its physical and chemical characteristics.

3 - SPOOL TYPE

Type S*:
2 solenoids - 3 positions
with spring centering

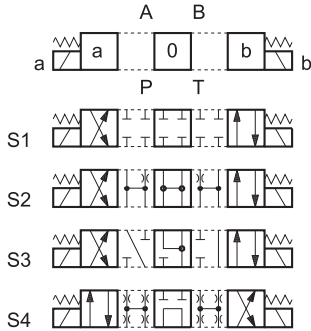

Type SA*:
1 solenoid side A
2 positions (central + external)
with spring centering

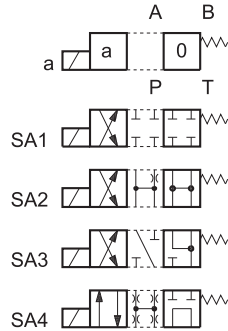

Type SB*:
1 solenoid side B
2 positions (central + external)
with spring centering

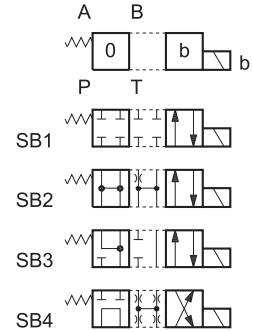

Type RK:
2 solenoids - 2 positions
with mechanical retention

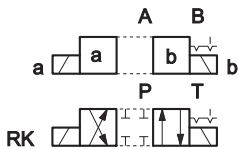

Type TA:
1 solenoid side A
2 external positions
with return spring

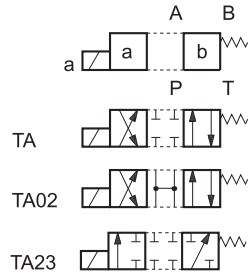

Type TB:
1 solenoid side B
2 external positions
with return spring

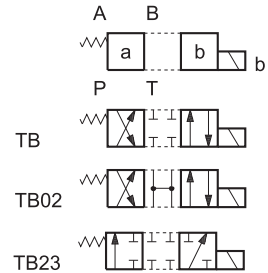

NOTE: Others spools available on request only.

4 - PRESSURE DROPS Δp -Q (obtained with viscosity of 36 cSt at 50 °C)

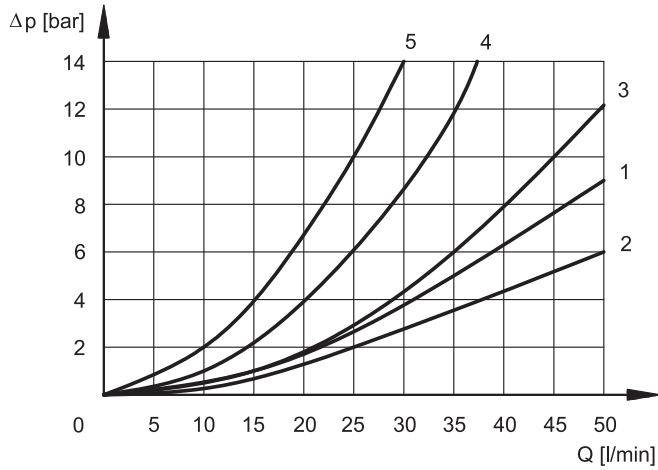

ENERGIZED VALVE

SPOOL	FLOW DIRECTIONS				
	P→A	P→B	A→T	B→T	P→T
	CURVES ON GRAPHS				
S1	1	1	1	1	-
S2	1	1	2	2	3
S3	3	3	2	2	-
S4	4	4	4	4	5
RK	1	1	1	1	-
TA	3	3	3	3	-

5 - OPERATING LIMITS

The curves define the flow rate operating fields according to the valve pressure of the different versions. The values indicated in the graphs are relevant to the standard solenoid valve. The operating limits can be considerably reduced if a 4-way valve is used as 3-way valve with port A or B plugged or without flow.

The values have been obtained according to ISO 6403 norm with solenoids at rated temperature and supplied with voltage equal to 90% of the nominal voltage. The value have been obtained with mineral oil, viscosity 36 cSt, temperature 50 °C and filtration according to ISO 4406:1999 class 18/16/13.

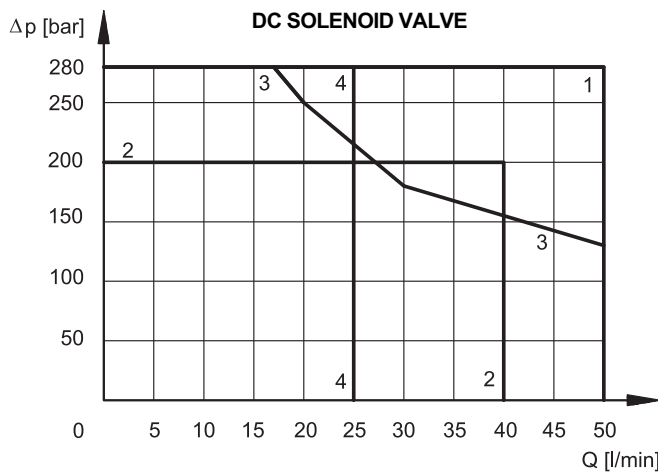

SPOOL	CURVE
S1, RK, TA	1
S2	2
S3	3
S4	4

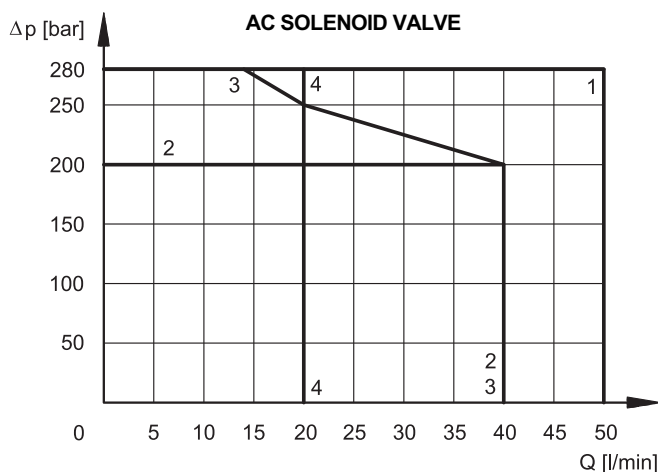

SPOOL	CURVE
S1, RK, TA	1
S2	2
S3	3
S4	4

6 - SWITCHING TIMES

The values indicated are obtained with spool S1, according to ISO 6403 standard, with mineral oil viscosity 36 cSt at 50°C.

SUPPLY	TIMES ($\pm 10\%$) [ms]	
	ENERGIZING	DE-ENERGIZING
DC	25 + 75	15 + 25
AC	10 + 25	15 + 30

7 - ELECTRICAL FEATURES

7.1 Solenoids

These are essentially made up of two parts: tube and coil. The tube is threaded into the valve body and includes the armature that moves immersed in oil, without wear. The inner part, in contact with the oil in the return line, ensures heat dissipation.

The coil is fastened to the tube by a threaded ring, and can be rotated +/- 90°, to suit the available space.

The interchangeability of coils of different voltages is allowed within the same type of supply current, alternating or direct.

Protection from atmospheric agents CEI EN 60529

Plug-in type	IP 65	IP 67	IP 69 K
K1 DIN 43650	x (*)		
K2 AMP JUNIOR	x	x (*)	
K4 outgoing cable	x	x	
K7 DEUTSCH DT04 male	x	x	x (*)
K8 AMP SUPER SEAL	x	x	x (*)

(*) The protection degree is guaranteed only with the connector correctly connected and installed

SUPPLY VOLTAGE FLUCTUATION	$\pm 10\%$ Vnom
MAX SWITCH ON FREQUENCY	10.000 ins/hr
DUTY CYCLE	100%
ELECTROMAGNETIC COMPATIBILITY (EMC)	In compliance with 2004/108/CE
LOW VOLTAGE	In compliance with 2006/95 CE
CLASS OF PROTECTION : Coil insulation (VDE 0580) Impregnation:	class H class H

NOTE: In order to further reduce the emissions, with DC supply, use of type H connectors is recommended. These prevent voltage peaks on opening of the coil supply electrical circuit (see cat. 49 000).

7.2 DC valve - Current and power consumption

In direct current energizing, current consumption stays at fairly constant values, essentially determined by Ohm's law: $V = R \times I$

"R" coil must be used when the valve is fed with AC power supply subsequently rectified by means of rectifier bridge, externally or incorporated in the "D" type connector (see cat. 49 000).

The table shows current and power consumption values for CC and RC coil types.

	Nominal voltage [V]	Resistance at 20°C [Ω] ($\pm 1\%$)	Current consumption [A] ($\pm 5\%$)	Power consumption ($\pm 5\%$)		Coil code				
				[W]	[VA]	K1	K2	K4	K7	K8
D12	12	5,4	2,2	26,5		1902740	1902750	1902770	1902980	1903020
D24	24	20,7	1,16	27,8		1902741	1902751	1902771	1902981	1903021
D28	28	27,5	1,02	28,5		1902744				
D48	48	82	0,58	28		1902745				
R110	110	363	0,25		27,2	1902742				
R230	230	1640	0,11		26,4	1902743				

7.3 AC valve - Current and power consumption

In alternating current energizing, an initial phase (maximum movement) is seen, during which the solenoid consumes elevated value currents (inrush current); the current values diminish during the plunger stroke until it reaches the minimum values (holding current) when the plunger reaches the stroke end. The table shows the values of absorption at the inrush and at holding.

	Nominal voltage [V]	Freq. [Hz]	Resistance at 20°C [Ω] (±5%)	Current consumption at inrush [A] (±10%)	Current consumption at holding [A] (±10%)	Power consumption at inrush (±10%) [VA]	Power consumption at holding (±10%) [VA]	Coil code K1
A24	24	50	2,7	4,5	1,47	109,2	35,3	1903190
A48	48		13,7	2,3	0,79	110,9	37,9	1903191
A110	110		73,4	1,0	0,31	107,8	34,1	1903192
A230	230		320	0,5	0,16	112,7	36,8	1903193

8 - DL3 DC OVERALL AND MOUNTING DIMENSIONS

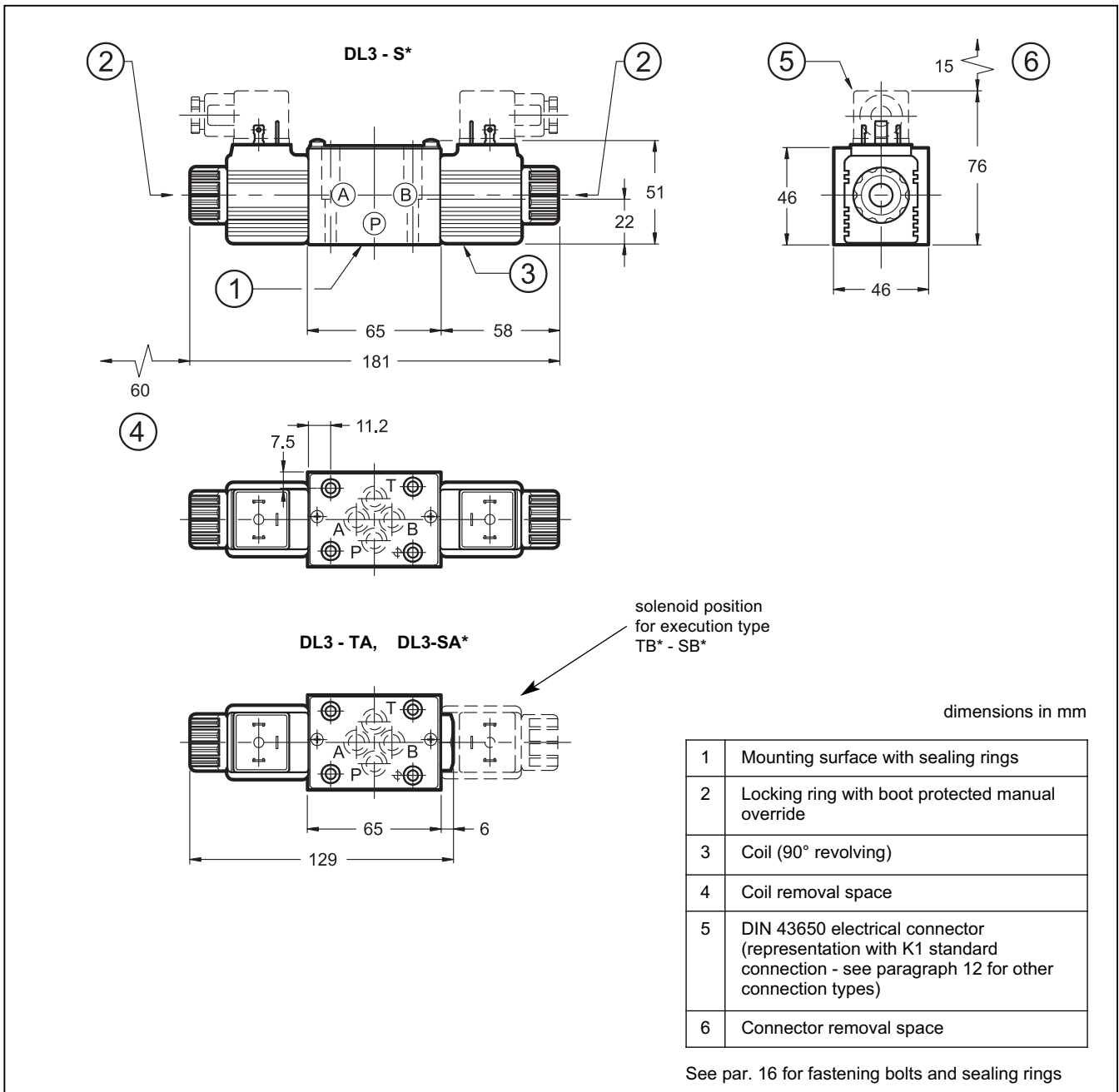

9 - DL3 AC OVERALL AND MOUNTING DIMENSIONS

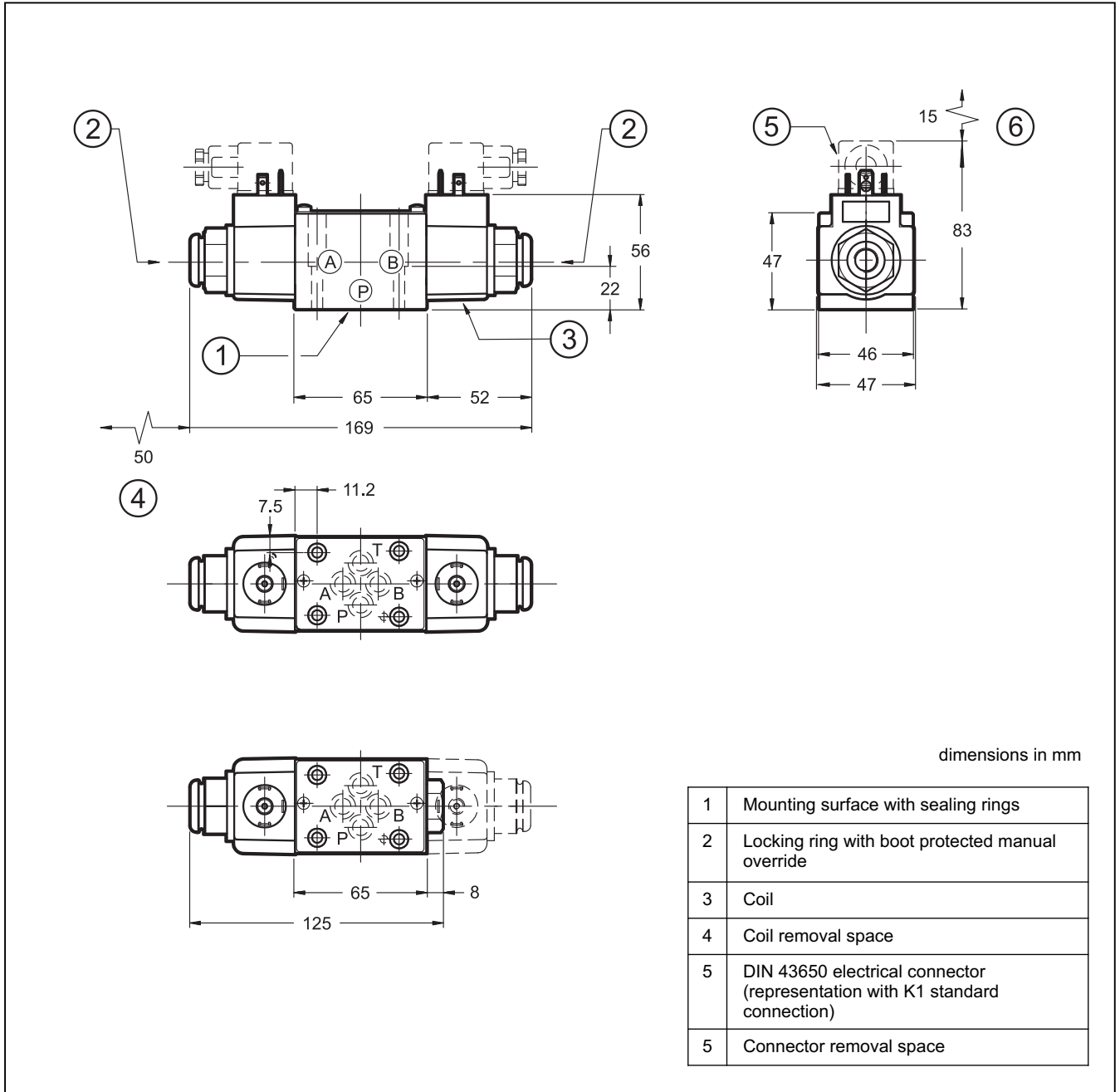

10 - INSTALLATION

Configurations with centering and return springs can be mounted in any position; type RK valves - without springs and with mechanical detent - must be mounted with the longitudinal axis horizontal.

Valve fitting takes place by means of screws or tie rods, fixing the valve on a lapped surface, with values of planarity and smoothness that are equal to or better than those indicated in the drawing.

If the minimum values of planarity or smoothness are not met, fluid leakages between valve and mounting surface can easily occur.

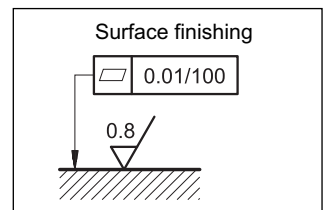

11 - OPTIONAL MANUAL OVERRIDES

11.1 - Boot protected manual override

On the DC version the boot override is integrated in the coil locking ring, as standard.

On the AC version, however, the boot override can be ordered by entering the code **CM** in the identification code at par. 1, or is available as option to be ordered separately: code **3401210001**.

11.2 - Knob manual override

Available only for DC version

When the set screw is screwed and its point is aligned with the edge of the knob, tighten the knob till it touches the spool: in this position the override is not engaged and the valve is de-energized. After adjusting the override, tighten the set screw in order to avoid the knob loosening.

Spanner: 2.5 mm

The knob override can be ordered by entering the code **CK** in the identification code at par. 1, or is available as option to be ordered separately: code **3401210002**.

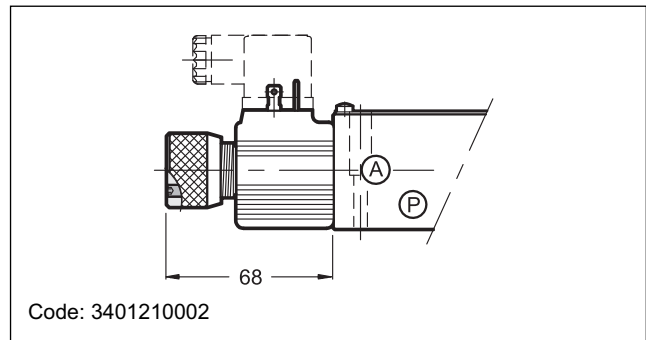
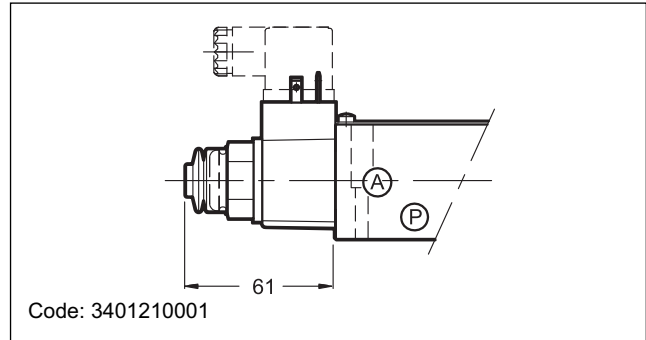

12 - ELECTRIC CONNECTIONS

connection for DIN 43650 connector type
code **K1 (standard)**

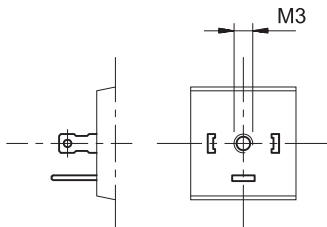

connection for AMP JUNIOR connector type
code **K2**

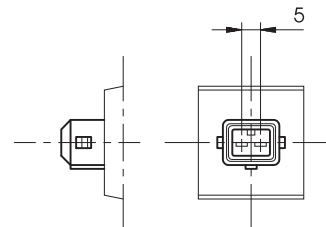

outgoing cable connections
code **K4**

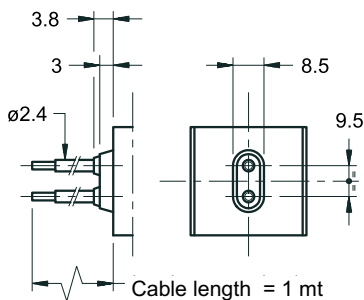

connection for DEUTSCH DT04-2P
for male connector type DEUTSCH DT06-2S
code **K7**

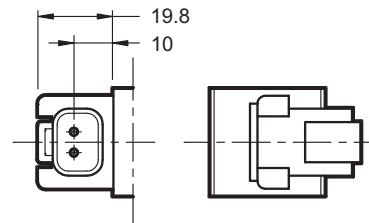

connection for AMP SUPER SEAL (two contacts)
connector type
code **K8**

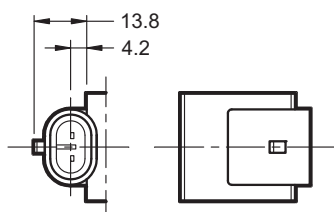

13 - ELECTRIC CONNECTORS

The solenoid operated valves are delivered without connector. For coils with standard electrical connections K1 type (DIN 43650) the connectors can be ordered separately. For the identification of the connector type to be ordered please see cat. 49 000. For K2, K7 and K8 connection type the relative connectors are not available.

14 - SPARE PARTS FOR DC SOLENOID VALVE

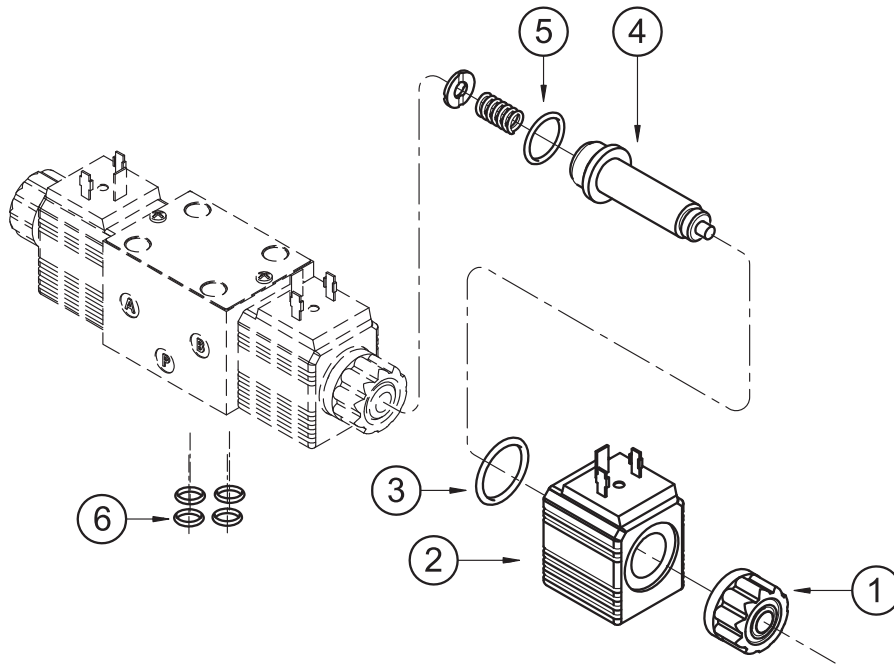

IDENTIFICATION CODE FOR DC AND RC COILS

C 14 L3 - / 10

Supply voltage
D12 = 12 V } direct current
D24 = 24 V }
D28 = 28 V }
D48 = 48 V }
R110 = 110 V } rectified current
R230 = 230 V }

Series no.:
 (the overall and mounting dimensions remain unchanged from 10 to 19)

Coil electrical connection:

- K1** = plug for connector type DIN 43650 (**standard**)
- K2** = plug for connector type AMP JUNIOR
- K4** = outgoing cables
- K7** = plug DEUTSCH DT04-2P for male connector type DEUTSCH DT06-2S
- K8** = plug for connector type AMP SUPER SEAL

1	Coil locking ring - code 0119382 tightening torque: 3 Nm
2	Coil (see identification code)
3	OR type 2112 (28.3x1.78)
4	Solenoid tube: TD14-M18/11N (NBR seals) TD14-M18/11V (FPM seals) (OR n° 5 included)
5	OR type 2062 (15.6x1.78) - 70 Shore
6	N. 4 OR type 2037 (9.25x1.78) - 90 Shore

SEAL KIT

The codes included the OR n° 5 and 6.

Cod. 1984435 NBR seals

Cod. 1984436 FPM seals

15 - SPARE PARTS FOR AC SOLENOID VALVE

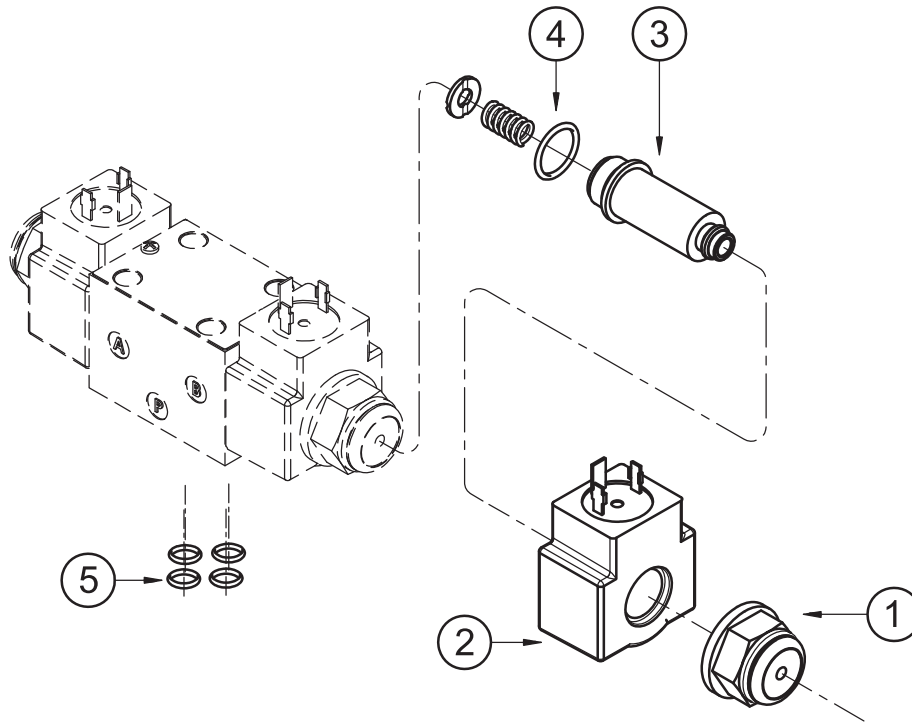

IDENTIFICATION CODE FOR AC COILS

C 18 L3 - K1 / 11

Supply voltage

A24 = 24 V - 50 Hz
A48 = 48 V - 50 Hz
A110 = 110 V - 50 Hz
A230 = 230 V - 50 Hz

Series no.:
 (the overall and
 mounting dimensions
 remain unchanged from
 10 to 19)

Coil electrical connection:
 plug for connector type
 DIN 43650

1	Coil locking ring - code. 0119469 tightening torque: 5 Nm
2	Coil (see identification code)
3	Solenoid tube: TA18-M18/11N (NBR seals) TA18-M18/11V (FPM seals) NOTE: OR n° 4 included.
4	OR type 2062 (15.6x1.78) - 70 Shore
5	N. 4 OR type 2037 (9.25x1.78) - 90 Shore

SEAL KIT

The codes included the OR n° 5 and 6.

Cod. 1984435 NBR seals

Cod. 1984436 FPM seals

16 - FASTENING BOLTS AND SEALING RINGS

Single valve fastening: 4 SHC screws M5x30 - ISO 4762

Tightening torque: 5 Nm

Threads of mounting holes: M5x10

Sealing rings: N. 4 OR type 2037 (9.25x1.78) - 90 Shore

17 - SUBPLATES (See catalogue 51 000)

Type PMMD-AI3G with rear ports

Type PMMD-AL3G with side ports

P, T, A, B port threading: 3/8" BSP



DIPLOMATIC OLEODINAMICA S.p.A.

20015 PARABIAGO (MI) • Via M. Re Depaolini 24

Tel. +39 0331.895.111

Fax +39 0331.895.339

www.diplomatic.com • e-mail: sales.exp@diplomatic.com