



DSC3

HYDRAULICALLY OPERATED DIRECTIONAL CONTROL VALVE

SERIES 10

SUBPLATE MOUNTING
DSC3 ISO 4401-03 (CETOP 03)

p max (see performances table)
Q nom (see performances table)

MOUNTING SURFACE

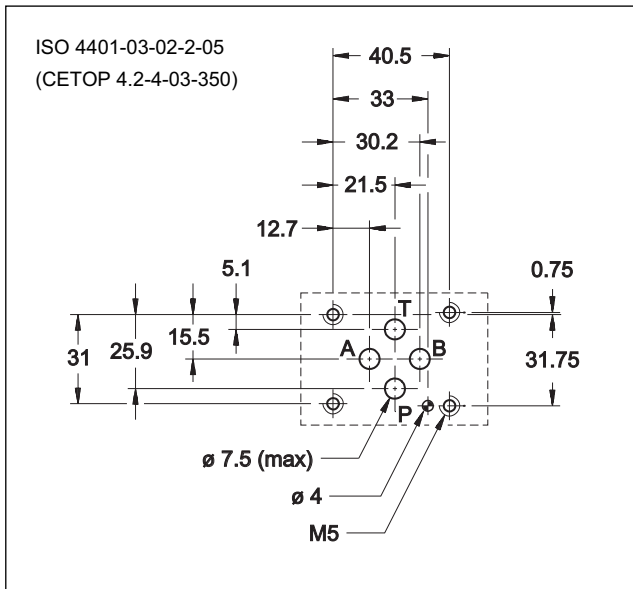

OPERATING PRINCIPLE

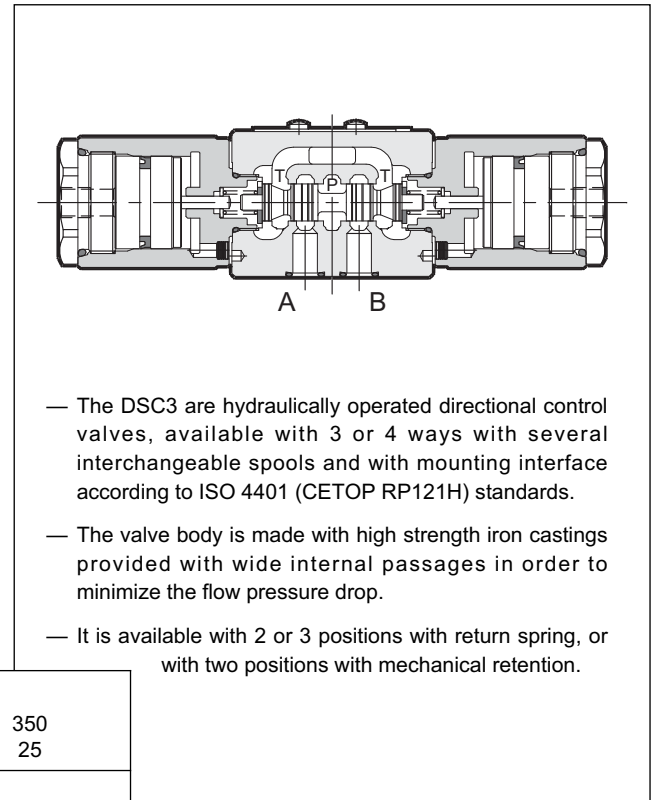

PERFORMANCES (measured with mineral oil of viscosity 36cSt at 50°C)

Maximum working pressure: - P A B ports - T port	bar	350 25
Piloting pressure - min - max	bar	15 (NOTE 1) 210
Nominal flowrate	l/min	75
Ambient temperature range	°C	-20 / +50
Fluid temperature range	°C	-20 / +80
Fluid viscosity range	cSt	10 ÷ 400
Fluid contamination degree	According to ISO 4406:1999 class 20/18/15	
Recommended viscosity	cSt	25
Mass: single operation valve double operation valve	kg	1,3 1,7

NOTE 1: The piloting pressure must be higher than the counterpressure on T port, of 15 bar at least: to allow the cursor reversal at middle the piloting pressure has to lower quickly at 0 bar.
The piston return spring generates a minimum backpressure of 0.5 bar on the piloting line.

1 - IDENTIFICATION CODE

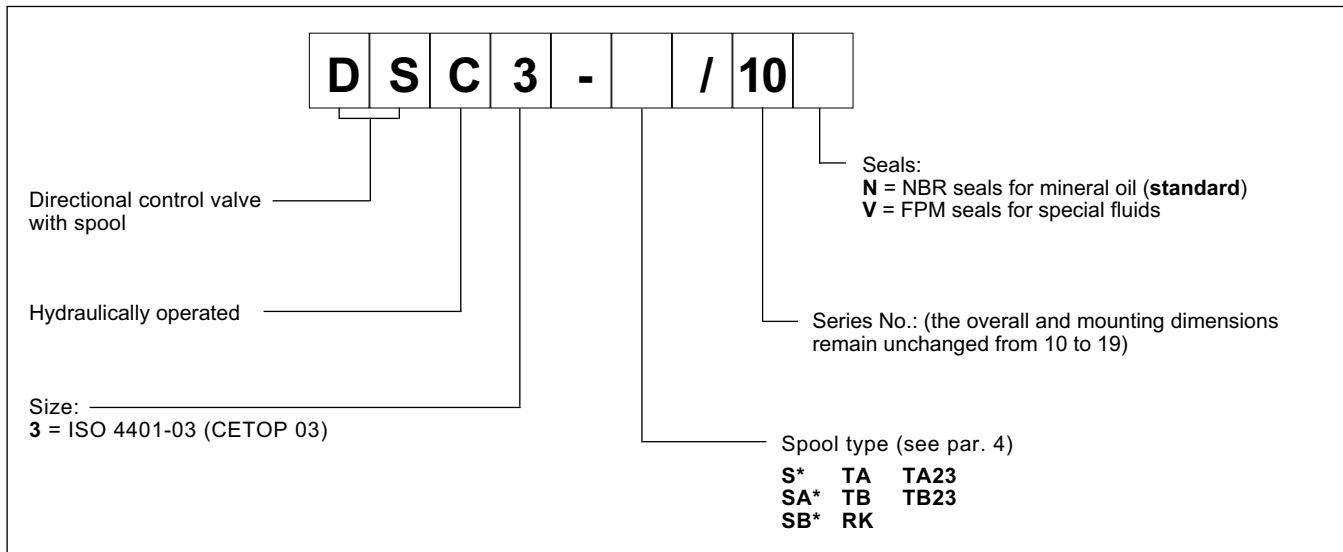

2 - HYDRAULIC FLUIDS

Use mineral oil-based hydraulic fluids HL or HM type, according to ISO 6743-4. For these fluids, use NBR seals (code N). For fluids HFDR type (phosphate esters) use FPM seals (code V).

For the use of other fluid types such as HFA, HFB, HFC, please consult our technical department. Using fluids at temperatures higher than 80 °C causes a faster degradation of the fluid and of the seals characteristics. The fluid must be preserved in its physical and chemical characteristics.

3 - SPOOL TYPE

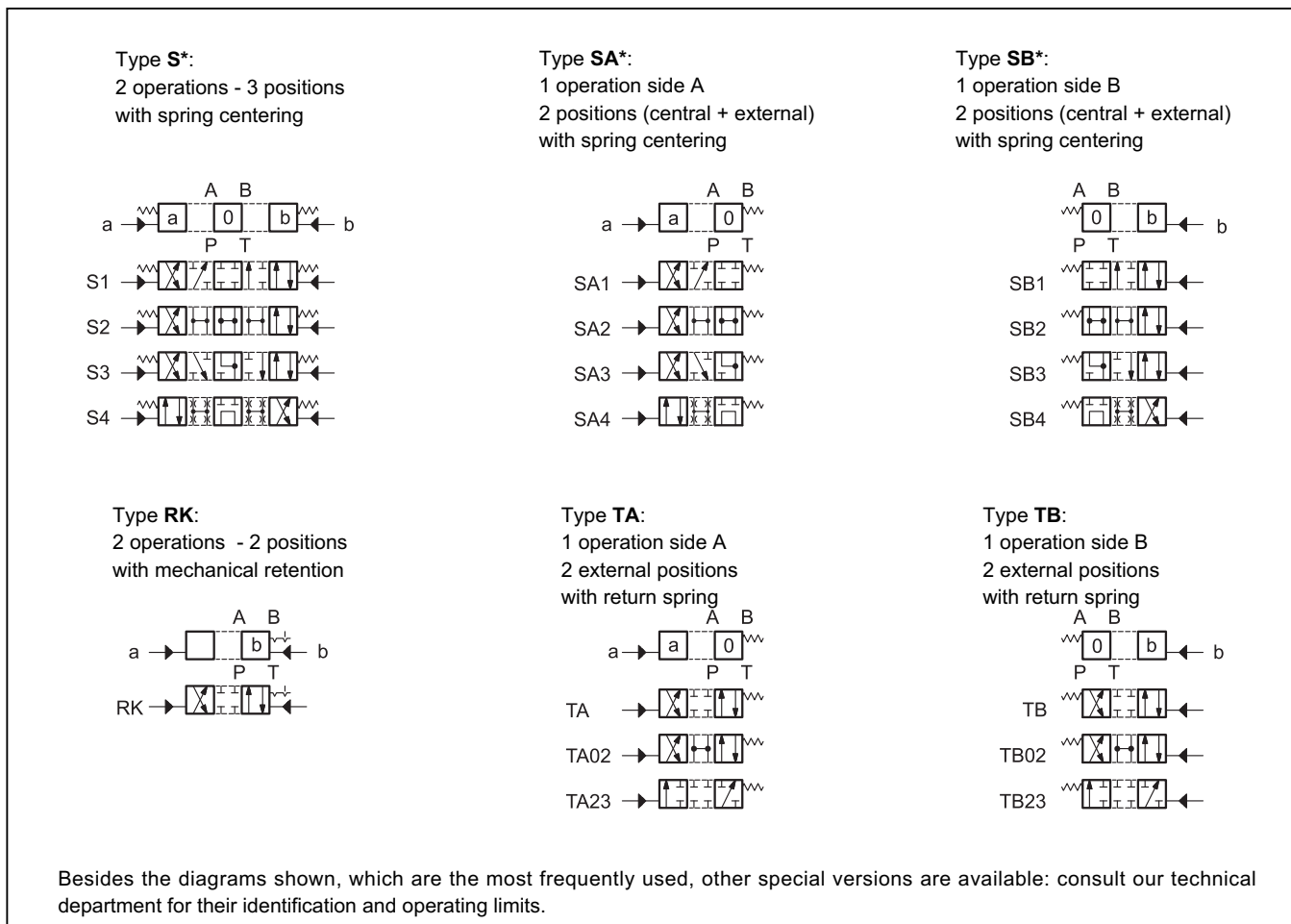

4 - PRESSURE DROPS Δp -Q (values obtained with viscosity 36 cSt at 50 °C)

4.1 - Pressure drops Δp -Q DSC3

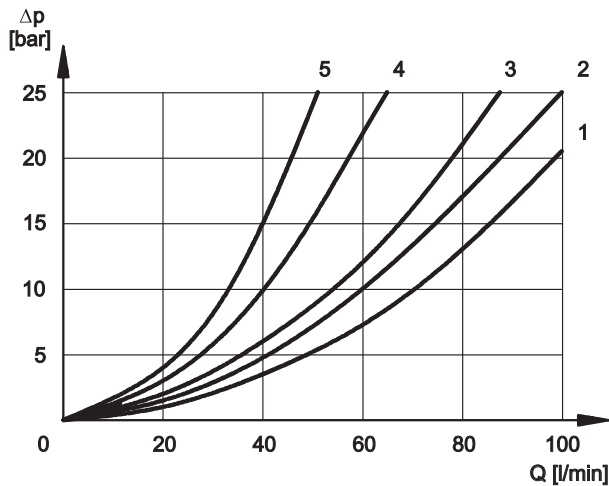

PRESSURE DROPS WITH VALVE IN ENERGIZED POSITION

SPOOL TYPE	FLOW DIRECTION			
	P-A	P-B	A-T	B-T
	CURVES ON GRAPH			
S1, SA1, SB1	2	2	3	3
S2, SA2, SB2	1	1	3	3
S3, SA3, SB3	3	3	1	1
S4, SA4, SB4	5	5	5	5
TA, TB	2	2	2	2
TA02, TB02	2	2	2	2
TA23, TB23	3	3		
RK	2	2	2	2

PRESSURE DROPS WITH VALVE IN DE-ENERGIZED POSITION

SPOOL TYPE	FLOW DIRECTION				
	P-A	P-B	A-T	B-T	P-T
	CURVES ON GRAPH				
S2, SA2, SB2					2
S3, SA3, SB3			3	3	
S4, SA4, SB4					4

5 - OPERATING LIMITS

The curves define the flow rate operating fields according to the valve pressure of the different versions. The values indicated in the graphs are relevant to the standard solenoid valve. The operating limits can be considerably reduced if a 4-way valve is used as 3-way valve with port A or B plugged or without flow. The values have been obtained according to ISO 6403 norm, with mineral oil viscosity 36 cSt at 50 °C and filtration according to ISO 4406:1999 class 18/16/13.

5.1 - Operating limits DSC3

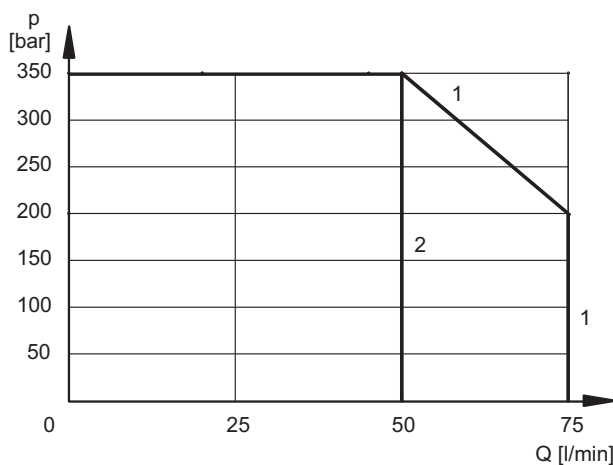

SPOOL TYPE	CURVE	
	P-A	P-B
S1,SA1,SB1	1	1
S2, SA2, SB2	2	2
S3, SA3, SB3	1	1
S4, SA4, SB4	2	2

SPOOL TYPE	CURVE	
	P-A	P-B
TA, TB	1	1
TA02, TB02	1	1
TA23, TB23	2	2
RK	1	1

6 - INSTALLATION

Configurations with centering and return springs can be mounted in any position; type RK valves - without springs and with mechanical detent - must be mounted with the longitudinal axis horizontal. Valve fixing is by means of screws or tie rods, with the valve mounted on a lapped surface, with values of planarity and smoothness that are equal to or better than those indicated in the drawing. If the minimum values of planarity and/or smoothness are not met, fluid leakage between valve and mounting surface can easily occur.

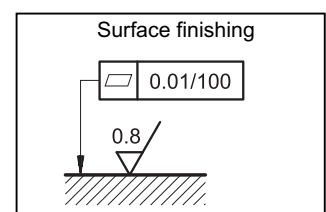

7 - OVERALL AND MOUNTING DIMENSIONS DSC3

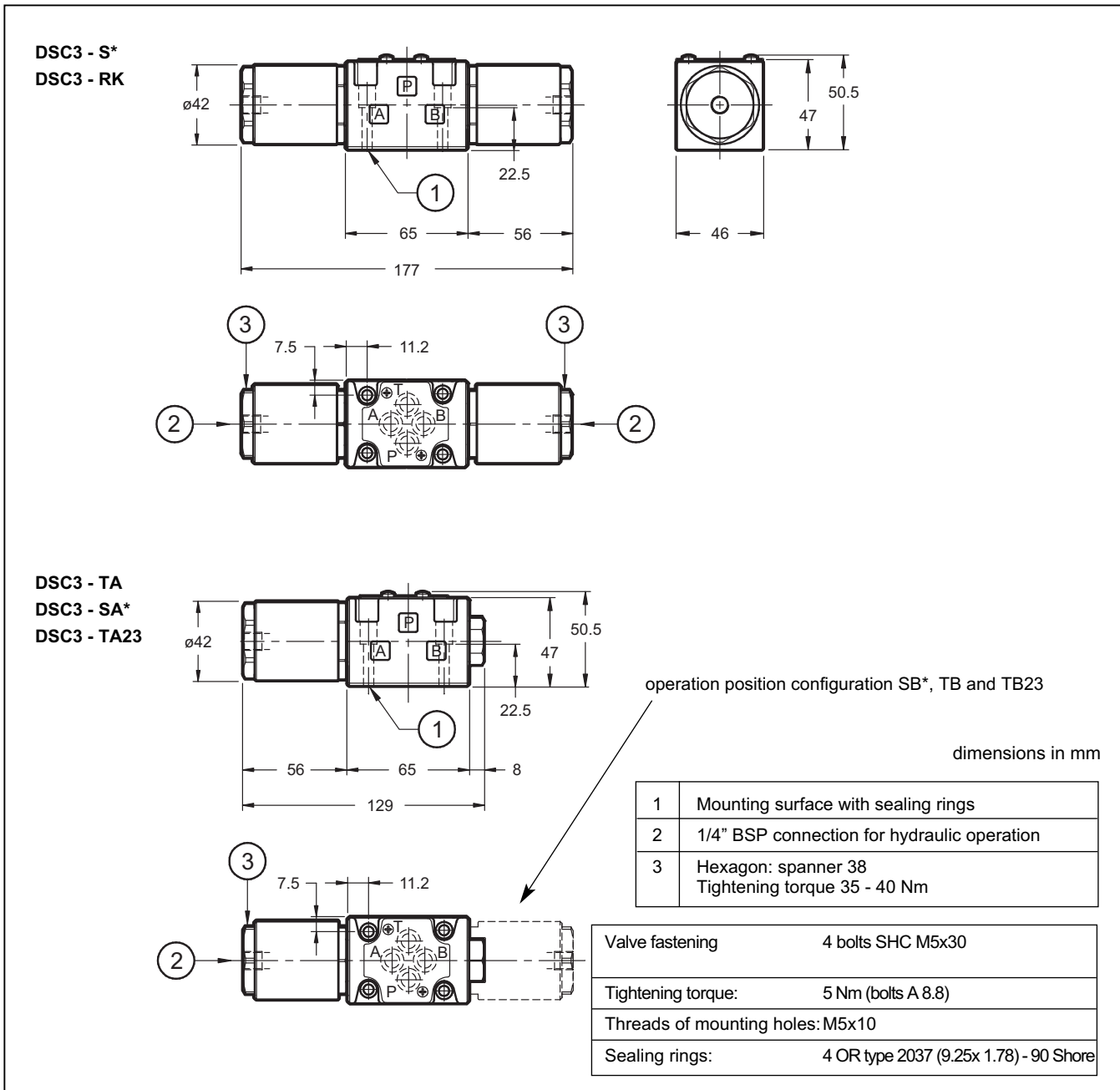

8 - SUBPLATES (see cat. 51 000)

Type with rear ports	PMMD-AI3G
Type with side ports	PMMD-AL3G
Threading of ports P, T, A, B,	3/8" BSP