



# LOGIC ELEMENTS

**SERIES 20**

**LC\* CARTRIDGE VALVES**  
**ISO 7368 - DIN 24342**

**LP\* COVERS**

**ND 16 - 25 - 32 - 40 - 50 - 63**

**p max 420 bar**

**Q max (see table of performances)**

## OPERATING PRINCIPLE

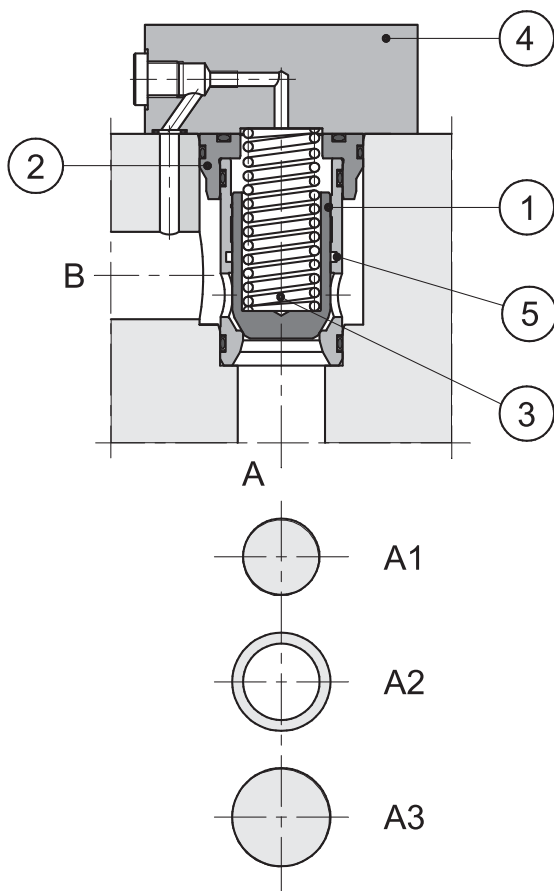

- Logic elements are cartridge valves suitable for installation in blocks or manifolds. They are available in five different sizes: ND 16 - 25 - 32 - 40 - 50 - 63.
- They are designed to perform complex hydraulic circuits, using functional compact blocks, with high flow rates and low pressure drops.
- They are made of a cartridge valve with ISO7368 / DIN 24342 cavity bore and a control cover (4). The cover includes the cartridge valves pilot lines; some versions are designed for the installation of ISO 4401-03 (CETOP 03) valves, to realise different control functions (see paragraph 8 for diagrams and function descriptions). A low leakage version is also available for sizes 25, 32, 40, 50 and 63 obtained inserting a seal into the seat no. 5.
- The cartridge valves are composed of a jacket (2), a poppet (1), and a closing spring (3). The poppet can either be standard (S) or with a damping nose (D), suitable for a smooth flow control during the valve opening and closing phases.
- There are two different types of cartridge valves available:
  - **Q type:** this valve is used for flow and directional control and as a check valve.  
The areas involved are:
    - $A_1$  - corresponding to the seat diameter area, considered as reference area = 1
    - $A_3$  - corresponding to the jacket internal diameter area.
    - $A_2$  - corresponding to the difference between  $A_3 - A_1$
 The area ratio  $A_1/A_3$  is 1/1,66.  
The valve opens when the pressure acting either on area  $A_1$  (flow from A to B) or on area  $A_2$  (flow from B to A) is higher than the pressure acting on area  $A_3$  (added to the spring load value).
  - **P type:** this valve is used for pressure control.  
In this case the areas  $A_1$  and  $A_3$  are equivalent (area ratio 1:1) and the valve enables the flow direction from A to B only.

## 1 - IDENTIFICATION CODE FOR CARTRIDGE VALVES

<b>L</b>	<b>C</b>	-		/	<b>N</b>	/	
----------	----------	---	--	---	----------	---	--

Cartridge valve

Shutter type:  
(area ratio  $A_1 / A_3$ ):  
**QS** = flow rate control (1:1,66)  
**QD** = flow rate control with damping nose (1:1,66)  
**PS** = pressure control (1:1)

**LL** = Low leakage version, with seal between C and B. Omit if not required.

Seals:  
NBR seals for mineral oil

**20** - for ND 16, 25, 32, 40 and 50  
**21** - for ND 63  
 (the overall and mounting dimensions remain unchanged from 20 to 29)

Nominal cracking pressure on section A1:  
**0.5** = 0,5 bar  
**1** = 1 bar (for ND 63 only)  
**2** = 2 bar (not available for ND 63)  
**4** = 4 bar  
 (other cracking pressure values available on request)

AVAILABLE NOMINAL SIZES						VERSIONS	SYMBOL
16 ND16	25 ND25	32 ND32	40 ND40	50 ND50	63 ND63		
x	x	x	x	x		<b>QS0.5</b>	
x	x	x	x	x	x	<b>QS2</b>	
x	x	x	x	x		<b>QD4</b>	
x	x	x	x	x	x	<b>PS1</b>  <b>PS2</b>	

## 2 - HYDRAULIC FLUIDS

Use mineral oil-based hydraulic fluids HL or HM type, according to ISO 6743-4. For these fluids, use NBR seals. For fluids HFDR type (phosphate esters) use FPM seals (code V). For the use of other kinds of fluid such as HFA, HFB, HFC, please consult our technical department. Using fluids at temperatures higher than 80 °C causes a faster degradation of the fluid and of the seals characteristics. The fluid must be preserved in its physical and chemical characteristics.



**3 - TECHNICAL CHARACTERISTICS (cartridge valve with control cover)**

Max operating pressure LC cartridge valve	bar	420
Max operating pressure limit of cover type DP*, DPE*, DF1, DF2, LCM	bar	350
Max operating pressure with distributor installed on cover	See technical characteristics of the distributor	
Ambient temperature range	°C	-20 / +50
Fluid temperature range	°C	-20 / +80
Fluid viscosity range	cSt	10 + 400
Fluid contamination degree	According to ISO 4406:1999 class 20/18/15	
Recommended viscosity	cSt	25

**3.1 - Cartridge valves type Q performances (flow control function)**

		NOMINAL SIZE							
		16	25	32	40	50	63		
Area A1	cm <sup>2</sup>	1,54	3	6	8,76	14,8	24,6		
Area A2	cm <sup>2</sup>	1	2	4	5,76	9,7	16,1		
Area A3	cm <sup>2</sup>	2,54	4,9	10	14,3	24,3	40,7		
Version S:	opening stroke h	cm	0,8	1	1,25	1,6	1,8	2,3	
	opening volume	cm <sup>3</sup>	2,03	4,9	12,5	22,88	43,74	96,26	
	max recommended flow	l/min	250	500	900	1300	2000	3000	
Version D:	opening stroke h	cm	0,8	1,15	1,5	1,8	2,2	2,7	
	opening volume	cm <sup>3</sup>	2,03	5,63	15	25,74	53,46	110	
	max recommended flow	l/min	200	450	800	1100	1700	2700	
Cracking pressure	A→B	spring 0,5	bar	0,5	0,5	0,5	0,5	0,5	-
		spring 2		2	2	2	2	2	2
		spring 4		4	4	4	4	4	-
	B→A	spring 0,5		0,9	1,1	0,7	0,76	0,8	-
		spring 2		3,1	3	3,1	3	3,2	3,2
		spring 4		6,15	5,9	5,4	5,9	5,9	-
Mass	Kg	0,25	0,5	1,1	1,9	3,9	7,8		

**3.2 - Cartridge valves type P performances (pressure control function)**

		NOMINAL SIZE						
		16	25	32	40	50	63	
Area A1 = Area A3	cm <sup>2</sup>	2,54	4,9	10	14,4	24,3	40,7	
Version S: max recommended flow	l/min	200	400	900	1000	1500	2500	
Cracking pressure	spring 1	bar	-	-	-	-	-	1
	spring 2		2	2	2	2	2	-
Mass	Kg	0,25	0,5	1,1	1,9	3,9	7,8	



**4 - CHARACTERISTIC CURVES** (values obtained with viscosity 36 cSt at 50°C)

**4.1 - LC\*-QS flow control function and LC\*-PS pressure control function**

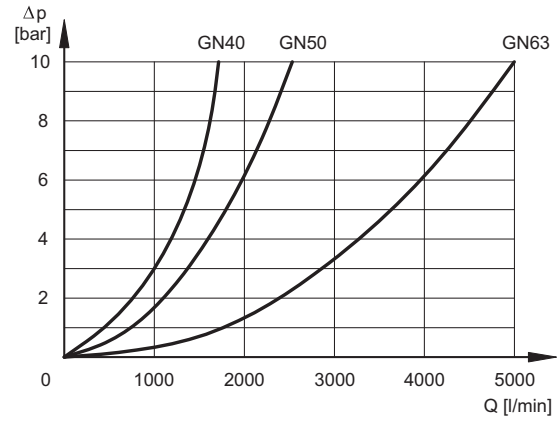
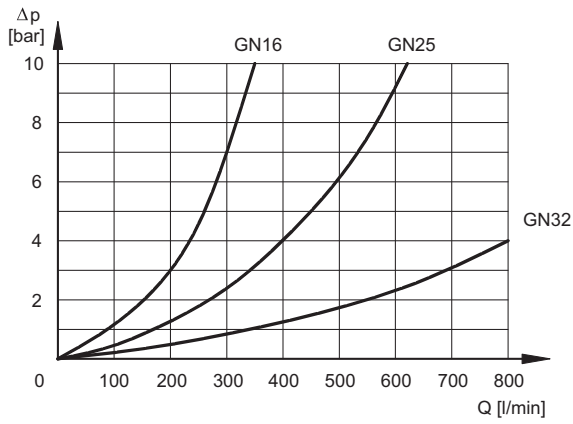

**4.2 - Flow control function with damping nose LC\*-QD**

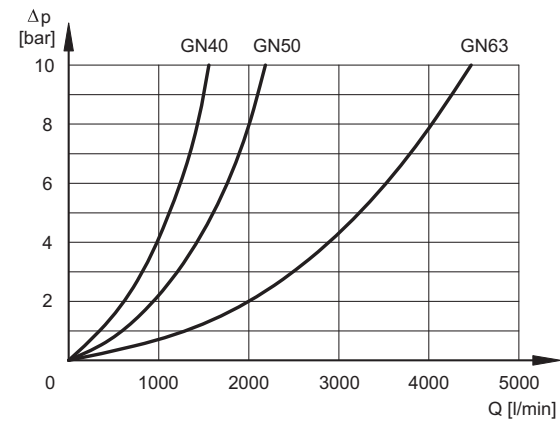
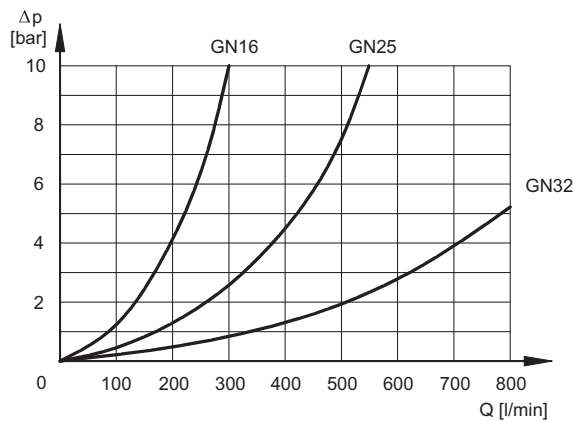

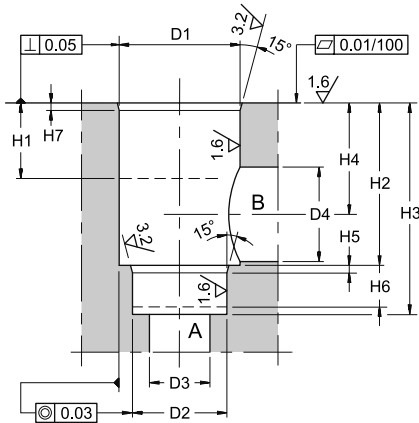
**5 - LC CARTRIDGE VALVES SEAT DIMENSIONS ACCORDING TO ISO 7368 / DIN 24342**

	LC CARTRIDGE VALVES NOMINAL SIZE					
	16	25	32	40	50	63
$\text{ØD1}^{\text{H7}}$	32	45	60	75	90	120
$\text{ØD2}^{\text{H7}}$	25	34	45	55	68	90
$\text{ØD3 max}$	16	25	32	40	50	63
$\text{ØD4}$	16	25	32	40	50	63
$\text{ØD4 max}$	25	32	40	50	63	80
H1 min	20	30	30	30	35	40
$\text{H2} \pm 0,1$	43	58	70	87	100	130
$\text{H3} \begin{matrix} +0,1 \\ 0 \end{matrix}$	56	72	85	105	122	155
H4 referred to diameter $\text{ØD4}$	34	44	52	64	72	95
H4 referred to diameter $\text{ØD4 max}$	29,5	40,5	48	59	65,5	86,5
H5	2	2,5	2,5	3	3	4
H6 min	11	12	13	15	17	20
H7	2	2,5	2,5	3	4	4

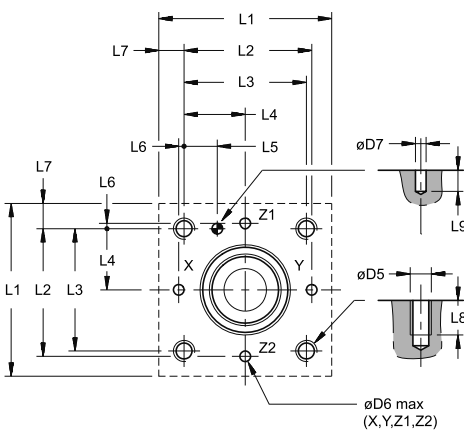
**6 - LP CONTROL COVERS INTERFACE DIMENSIONS ACCORDING TO ISO 7368 / DIN 24342**

	LP CONTROL COVERS NOMINAL SIZE					
	16	25	32	40	50	63
$\text{ØD5}$	M8	M12	M16	M20	M20	M30
$\text{ØD6 max}$	4	6	8	10	10	12
$\text{ØD7}^{\text{H13}}$	4	6	6	6	8	8
L1	*	85	100	125	140	180
$\text{L2} \pm 0,1$	48	62	76	92,5	108	137,5
$\text{L3} \pm 0,1$	46	58	70	85	100	125
$\text{L4} \pm 0,1$	23	29	35	42,5	50	62,5
$\text{L5} \pm 0,1$	12,5	13	18	19,5	20	24,5
$\text{L6} \pm 0,1$	2	4	6	7,5	8	12,5
L7	*	13,5	15	20	20	27,5
L8 min	15	20	28	35	35	52
L9 min	8	8	8	8	8	8

\* = cover with special dimensions (see par. 9.2, 9.7)

## 7 - COVERS IDENTIFICATION CODE

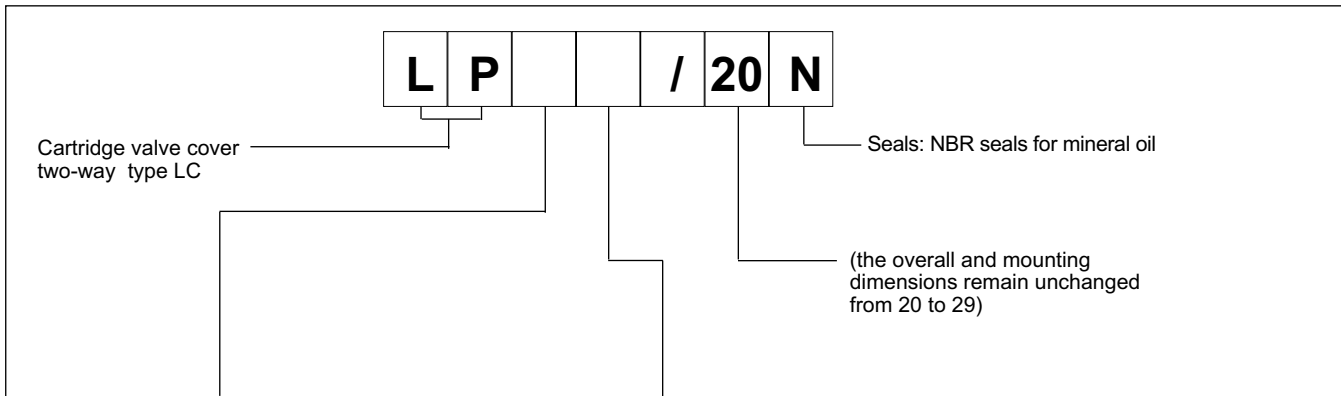

AVAILABLE NOMINAL SIZES						COVER NAME	SYMBOL	DIAGRAM PARAGRAPH	OVERALL DIMENSIONS PARAGRAPH
16 ND16	25 ND25	32 ND32	40 ND40	50 ND50	63 ND63				
X	X	X			X	R		8.1	9.1
X	X	X	X	X	X	D		8.2	9.2
X	X	X	X			DZ		8.3	9.3
X	X	X	X	X		DF1		8.4	9.4
X	X	X	X			DF2		8.5	9.5
X	X	X	X	X		Q		8.6	9.6
X	X	X	X	X	X	DP*		8.7	9.7
X	X	X	X	X		DPE*		8.8	9.7

## 8 - FUNCTIONAL DIAGRAMS

### 8.1 - R cover for directional control and check valve function with external pilot X

Functional diagrams	Description
	<p>Piloting of the cartridge valve through the X port, available on the mounting surface or with pipe connection 1/4" BSP.</p> <p>For ND 40 and ND 50 sizes, the external piloting function can be realised by using control cover type D, with blanking plate code <b>1950751</b> (to be ordered separately).</p>

### 8.2 - D cover for directional control and check valve function

Functional diagrams	Description
	<p>Piloting of the cartridge valve by means of solenoid valve type <b>DS3-TA</b> (to be ordered separately - see catalogue 41 150)</p> <ul style="list-style-type: none"> <li>- solenoid valve OFF = A ↔ B intercepted flow</li> <li>- solenoid valve ON = A ↔ B free flow</li> </ul>

### 8.3 - DZ cover for directional control with possibility to pilot other cartridges in line

Functional diagrams	Description
	<p>The DZ cover enables the piloting of its cartridge valves and also of other valves connected to Z1 and Z2 pilot lines.</p> <p>The solenoid valve type <b>DS3-S10</b> must be ordered separately (see catalogue 41 150).</p>

### 8.4 - DF1 cover for directional control and check function with double pilot line

Functional diagrams	Description
	<p>The DF1 cover gives the possibility of a double pilot line through X and Z1 ports.</p> <p>The solenoid valve type <b>DS3-TA</b> must be ordered separately (see catalogue 41 150).</p> <ul style="list-style-type: none"> <li>- solenoid valve OFF = A ↔ B intercepted flow</li> <li>- solenoid valve ON = A → B free flow , B → A intercepted (if pilot line X is connected with B and if Z1 is connected with A).</li> </ul>

**8.5 - DF2 cover for directional control and check function with priority piloting from two external lines**

Functional diagrams	Description
	<p>The cartridge valve can be simultaneously piloted from X and Z1 lines.</p> <p>The shuttle valve, integrated in the cover, enables the automatic selection of the pilot line which has the higher pressure (priority line).</p> <p>The solenoid valve type <b>DS3-TA</b> must be ordered separately (see catalogue 41 150).</p> <ul style="list-style-type: none"> <li>- solenoid valve OFF = A ↔ B intercepted flow</li> <li>- solenoid valve ON = A ↔ B free flow</li> </ul>

**8.6 - Q cover for flow control function**

Functional diagrams	Description
	<p>Flow control function by means of cover with stroke limiter.</p> <p>For a better flow control and to avoid the wear of the valve seat, this cover is normally used with a QD4 cartridge type.</p>

**8.7 - DP\* cover for pressure control function**

Functional diagrams	Description
	<p>Pressure control function with a built-in relief valve.</p> <ul style="list-style-type: none"> <li>- max. adjustment pressure DP4 = 140 bar - DP6 = 350 bar</li> </ul> <p>The top blanking plate code 1950591 must be ordered separately.</p>
	<p>Pressure control function with electrical unloading by means of <b>DS3-SA2</b> solenoid valve (to be ordered separately - see catalogue 41 150).</p> <ul style="list-style-type: none"> <li>- solenoid valve OFF = unloading at minimum pressure</li> <li>- solenoid valve ON = pressure controlled by the built-in relief valve.</li> </ul>
	<p>Pressure control function with electrical unloading and two step pressure by means of the solenoid valves <b>DS3-S2</b> (to be ordered separately - see catalogue 41 150), <b>MCI*-SAT/10</b> (for 16, 24 and 32 sizes - to be ordered separately) and <b>MCD*-SAT</b> (for 40, 50 and 63 sizes to be ordered separately - see catalogue 61 200)</p> <ul style="list-style-type: none"> <li>- solenoid valve OFF = unloading at minimum pressure</li> <li>- solenoid valve ON side a = pressure controlled by the relief valve (<b>MCI*</b> or <b>MCD*</b>).</li> <li>- solenoid valve ON side b = pressure controlled by the relief valve integrated in the cover.</li> </ul>

	<p>Pressure control function with electrical control and three steps pressure by means of the solenoid valves <b>DS3-S3</b> (to be ordered separately - see catalogue 41 150), <b>MCI*-DT/10</b> (for 16- 24 and 32 sizes - to be ordered separately) and <b>MCD*-DT/51</b> (for 40 and 50 sizes - to be ordered separately - see catalogue 61 200)</p> <ul style="list-style-type: none"> <li>- solenoid valve OFF = pressure controlled by the cover relief valve.</li> <li>- solenoid valve ON side a = pressure controlled by the relief valve on side b.</li> <li>- solenoid valve ON side b = pressure controlled by the relief valve on side a.</li> </ul>
--	---

8.7 - DPE\* cover for pressure control function

Functional diagram	Description
	<p>Pressure control function by means of <b>PRED3</b> proportional valve (to be ordered separately see catalogue 81 210).</p> <ul style="list-style-type: none"> <li>- Proportional valve OFF = unloading at minimum pressure</li> <li>- Proportional valve ON = proportional control of pressure</li> </ul>

**9 - OVERALL AND MOUNTING DIMENSIONS FOR CONTROL COVERS**

**9.1 - R type covers**

dimensions in mm

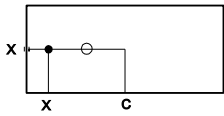

LP16R  
LP25R  
LP32R  
LP63R

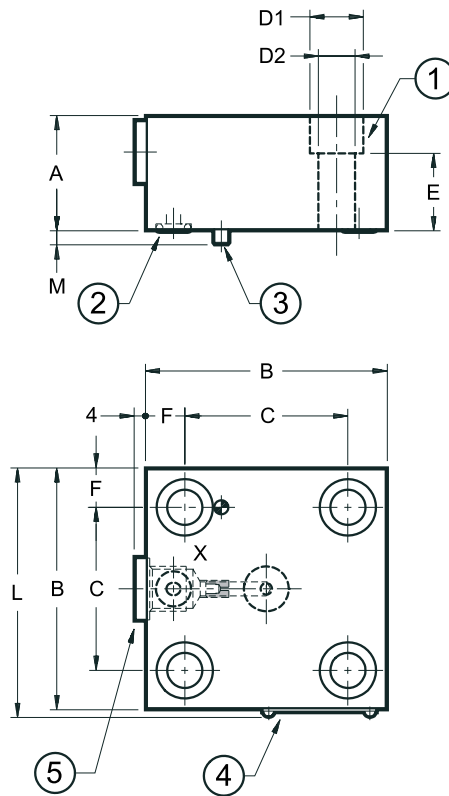

	NOMINAL SIZE			
	16	25	32	63
A	30	30	40	70
B	65	85	100	180
C	46	58	70	125
D1	13,5	19	25	46
D2	8,5	13	17	31
E	19	17	22	35
F	9,5	13,5	15	27,5
L	67,5	87,5	102,5	182,5
M	4	5	5	5

ports ready for restrictors	port X			
restrictors	M6x8		M10x10	
Mass [Kg]	1,20	2,30	4,00	17,5

1	N. 4 fastening bolts ( <b>NOTE</b> ): 16 = M8x30 25 = M12x35 32 = M16x45 63 = M30x80
2	N. 1 sealing ring 90 Shore: 16 = OR type 2025 (6.07x1.78) 25 = OR type 2037 (9.25x1.78) 32 = OR type 2037 (9.25x1.78) 63 = OR type 2056 (14.00x1.78)
3	Locating pin: 16 = Ø3x10      25 = Ø5x14 32 = Ø5x14      63 = Ø6x14
4	Identification label
5	Plug X: 1/4" BSP

**NOTE:** Fastening bolts class 12.9 UNI 5931 are recommended for the installation of the cover (to be ordered separately)

9.2 - Covers type D

dimensions in mm

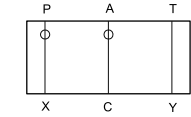

LP16D  
LP25D  
LP32D  
LP40D  
LP50D  
LP63D

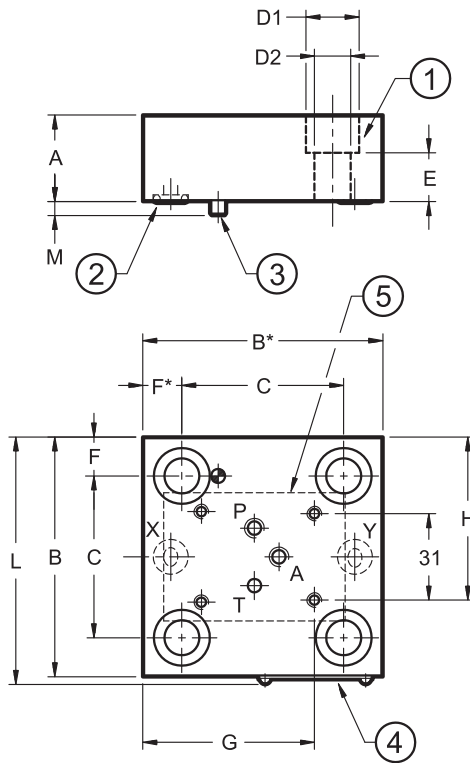

	NOMINAL SIZE					
	16	25	32	40	50	63
A	30	30	40	40	50	70
B	65	85	100	125	140	180
B*	75	85	100	125	140	180
C	46	58	70	85	100	125
D1	13,5	19	25	31	31	46
D2	8,9	13	17	21	21	31
E	19	17	22	30	30	35
F	9,5	13,5	15	20	20	27,5
F*	19,5	13,5	15	20	20	27,5
G	52	60,2	65,2	73,2	82,7	111,5
H	48	58	65,5	78	85,5	105,5
L	67,5	87,5	102,5	127,5	142,5	182,5
M	4	5	5	5	5	7

ports ready for restrictors	P, A					
restrictors	M6x8					M8x8
Mass [Kg]	1,20	2,30	4,00	4,80	7,6	17,5

1	N. 4 fastening bolts ( <b>NOTE</b> ): <b>16</b> = M8x30 <b>25</b> = M12x35 <b>32</b> = M16x45 <b>40</b> = M20x50 <b>50</b> = M20x60 <b>63</b> = M30x80
2	n° 2 sealing rings 90 Shore : <b>16</b> = OR type 2025 (6.07x1.78) <b>25</b> = OR type 2037 (9.25x1.78) <b>32</b> = OR type 2037 (9.25x1.78) <b>40</b> = OR type 2050 (12.42x1.78) <b>50</b> = OR type 2050 (12.42x1.78) <b>63</b> = OR type 2056 (14x1.78)
3	Locating pin: <b>16</b> = Ø3x10 <b>25</b> = Ø5x14 <b>32</b> = Ø5x14 <b>40</b> = Ø5x14 <b>50</b> = Ø6x14 <b>63</b> = Ø6x14
4	Identification label
5	Mounting surface ISO 4401-03 (CETOP 4.2-4-03-350)

**NOTE:** Fastening bolts class 12.9 UNI 5931 are recommended for the installation of the cover (to be ordered separately)

### 9.3 - Covers type DZ

dimensions in mm

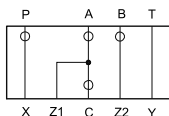

LP16DZ  
LP25DZ  
LP32DZ  
LP40DZ

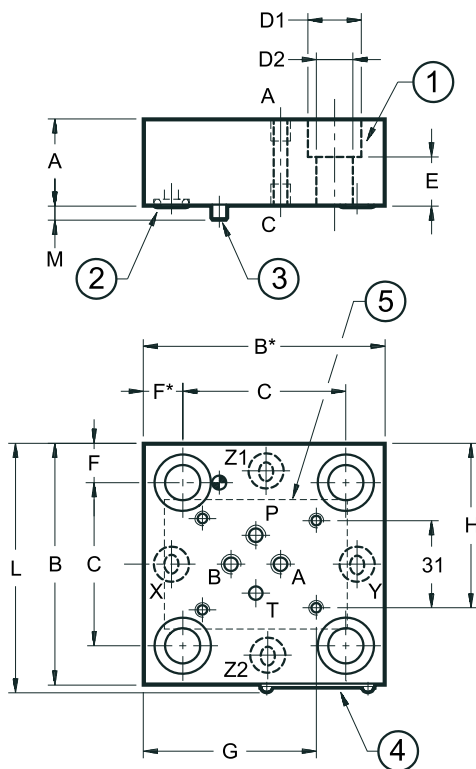

	NOMINAL SIZE			
	16	25	32	40
A	30	30	40	50
B	65	85	100	125
B*	75	85	100	125
C	46	58	70	85
D1	13,5	19	25	31
D2	8,9	13	17	21
E	19	17	22	30
F	9,5	13,5	15	20
F*	19,5	13,5	15	20
G	52	60,2	65,2	84
H	48	58	65,5	78
L	67,5	87,5	102,5	127,5
M	4	5	5	5

ports ready for restrictors M6x8	P, A, B, C			
Mass [Kg]	1,20	2,30	4,00	4,3

1	N. 4 fastening bolts ( <b>NOTE</b> ): <b>16</b> = M8x30 <b>25</b> = M12x35 <b>32</b> = M16x45 <b>40</b> = M20x50
2	n° 4 sealing rings 90 Shore : <b>16</b> = OR type 2025 (6.07x1.78) <b>25</b> = OR type 2037 (9.25x1.78) <b>32</b> = OR type 2037 (9.25x1.78) <b>40</b> = OR type 2050 (12.42x1.78)
3	Locating pin: <b>16</b> = Ø3x10 <b>25</b> = Ø5x14 <b>32</b> = Ø5x14 <b>40</b> = Ø5x14
4	Identification label
5	Mounting surface ISO 4401-03 (CETOP 4.2-4-03-350)

**NOTE:** Fastening bolts class 12.9 UNI 5931 are recommended for the installation of the cover (to be ordered separately)

**9.4 - Covers type DF1**

dimensions in mm

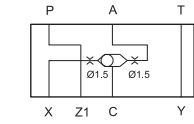

LP16DF1

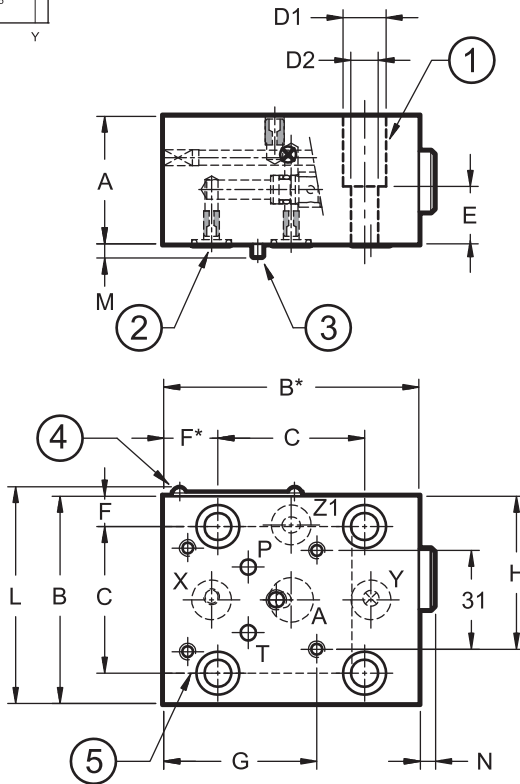

	NOMINAL SIZE				
	16	25	32	40	50
A	40	40	40	50	50
B*	80	85	102	125	140
B	65	85	102	125	140
C	46	58	70	85	100
D1	13,5	19	25	31	31
D2	8,5	13	17	21	21
E	18	17	22	30	30
F*	17	13,5	16	20	20
F	9,5	13,5	16	20	20
G	47,5	64	72,5	84	91,5
H	48	58	66,5	78	85,5
L	67,5	87,5	104,5	127,5	142,5
M	4	5	5	5	5
N	4,5	3,5	3,5	-	-

Mass [Kg]	1,8	2,3	4	6,7	7,6
-----------	-----	-----	---	-----	-----

LP25DF1  
LP32DF1  
LP40DF1  
LP50DF1

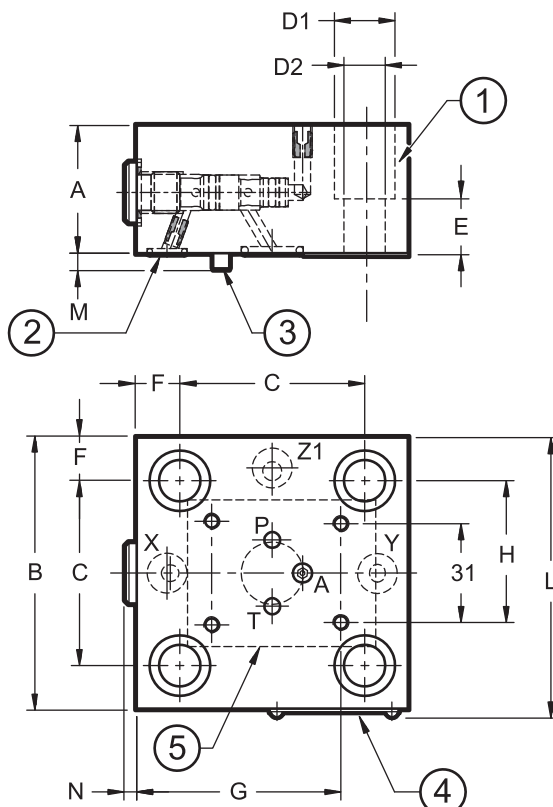

1	N. 4 fastening bolts ( <b>NOTE</b> ): <b>16</b> = M8x30 <b>25</b> = M12x35 <b>32</b> = M16x45 <b>40</b> = M20x60 <b>50</b> = M20x60
2	N° 3 sealing rings 90 Shore : <b>16, 25</b> and <b>32</b> = OR type 2037 (9.25x1.78) <b>40</b> and <b>50</b> = OR type 2050 (12.42x1.78)
3	Locating pin <b>16</b> = Ø3x10 <b>25, 32, 40</b> and <b>50</b> = Ø5x14
4	Identification label
5	Mounting surface ISO 4401-03 (GETOP 4.2-4-03-350)

**NOTE:** Fastening bolts class 12.9 UNI 5931 are recommended for the installation of the cover (to be ordered separately)

### 9.5 - Covers type DF2

dimensions in mm

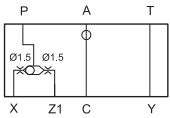

LP16DF2  
LP25DF2  
LP32DF2  
LP40DF2

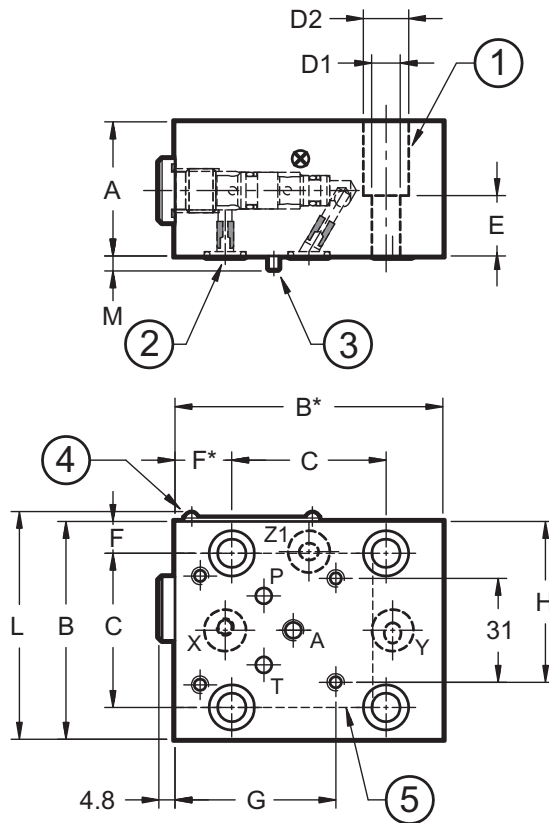

	NOMINAL SIZE			
	16	25	32	40
A	40	40	40	50
B	65	85	102	125
B*	80	85	102	125
C	46	58	70	85
D1	13,5	19	25	31
D2	8,5	13	17	21
E	18	17	22	30
F	9,5	13,5	16	20
F*	17	13,5	16	20
G	48	61	68,7	81
H	48	58	65,5	71,2
L	67,5	87,5	102,5	104,5
M	4	5	5	5

ports ready for restrictors M6x8	A			
Mass [Kg]	1,8	2,3	4	6,7

1	N. 4 fastening bolts ( <b>NOTE</b> ): <b>16</b> = M8x30 <b>25</b> = M12x35 <b>32</b> = M16x45 <b>40</b> = M20x60
2	N° 3 sealing rings 90 Shore : OR type 2037 (9.25x1.78)
3	Locating pin <b>16</b> = Ø3x10 <b>25, 32 e 40</b> = Ø5x14
4	Identification label
5	Mounting surface ISO 4401-03 (CETOP 4.2-4-03-350)

**NOTE:** Fastening bolts class 12.9 UNI 5931 are recommended for the installation of the cover (to be ordered separately)

**9.6 - Covers type Q**

dimensions in mm

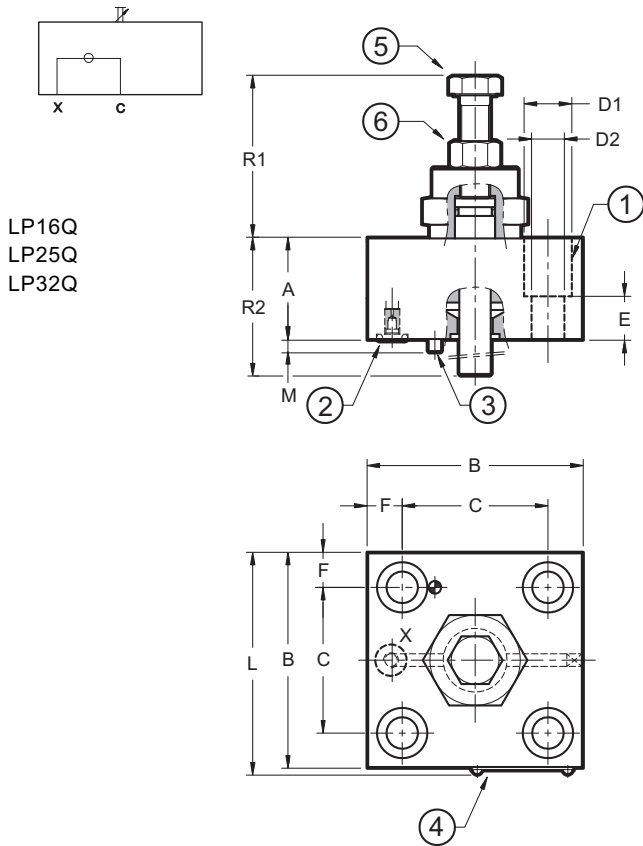

LP16Q  
LP25Q  
LP32Q

	NOMINAL SIZE				
	16	25	32	40	50
A	35	40	40	60	60
B	65	85	100	125	140
C	46	58	70	85	100
D1	13,5	19	25	31	31
D2	9	13	17	21	21
E	18	17	22	30	40
F	9,5	13,5	15	20	20
L	67,5	87,5	102,5	127,5	142,5
M	4	5	5	5	
R1	57 + 64,5	55 + 64,5	57 + 74	38,3+56,3	44,5+66,5
R2	67 + 75	83 + 94	90 + 105	138,7+121,7	128+150,2

ports ready for restrictors M6x8	port X				
Mass [Kg]	1,20	2,30	4,00	7,40	-

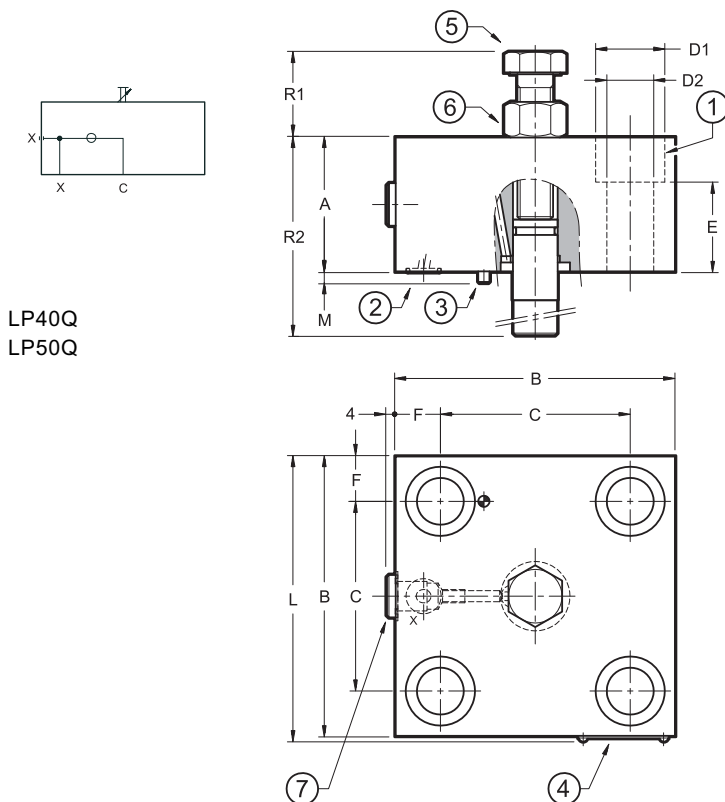

LP40Q  
LP50Q

1	N. 4 fastening bolts ( <b>NOTE</b> ): <b>16</b> = M8x30 <b>25</b> = M12x35 <b>32</b> = M16x35 <b>40</b> = M20x70 <b>50</b> = M20x70
2	n° 1 sealing ring 90 Shore: <b>16</b> = OR type 2025 (6.07x1.78) <b>25</b> = OR type 2037 (9.25x1.78) <b>32</b> = OR type 2037 (9.25x1.78) <b>40</b> = OR type 2050 (12.42x1.78) <b>50</b> = OR type 2087 (21.95x1.78)
3	Locating pin: <b>16</b> = Ø3x10 <b>25</b> = Ø5x14 <b>32</b> = Ø5x14 <b>40</b> = Ø5x14 <b>50</b> = Ø6x14
4	Identification label
5	Plug X: <b>40</b> = 1/4" BSP <b>50</b> = 1/4" BSP
6	Stroke limiter clockwise rotation to reduce stroke <b>16</b> = 1 turn: 1,25 mm - spanner 18 <b>25</b> = 1 turn: 1,25 mm - spanner 18 <b>32</b> = 1 turn: 1,25 mm - spanner 18 <b>40</b> = 1 turn: 1,50 mm - spanner 24 <b>50</b> = 1 turn: 1,50 mm - spanner 30
7	Locking nut: <b>16</b> = spanner 18 <b>25</b> = spanner 18 <b>32</b> = spanner 18 <b>40</b> = spanner 24 <b>50</b> = spanner 30

**NOTE:** Fastening bolts class 12.9 UNI 5931 are recommended for the installation of the cover (to be ordered separately)

### 9.7 - Covers type DP\* and DPE\*

dimensions in mm

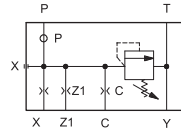
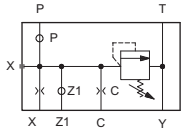

LP16DP\*  
LP25DP\*  
LP32DP\*  
LP40DP\*  
LP50DP\*  
LP63DP\*

LP16DPE\*  
LP25DPE\*  
LP32DPE\*  
LP40DPE\*  
LP50DPE\*

	NOMINAL SIZE					
	16	25	32	40	50	63
A	40	40	40	50	50	70
B	65	85	100	125	140	180
B*	75	85	100	125	140	180
C	46	58	70	85	100	125
D1	13,5	19	25	31	31	46
D2	8,5	13	17	21	21	31
E	18	17	22	30	30	35
F	9,5	13,5	15	20	20	27,5
F*	19,5	13,5	15	20	20	27,5
G	52	64	71,5	84	91,5	102,7
H	48	58	65,5	78	85,5	105,5
L	67,5	87,5	102,5	127,5	142,5	182,5
M	4	5	5	5	5	5
N	24	25	25	25	25	35
R	45÷ 51,5	45÷ 51,5	45÷ 51,5	44 ÷ 52	44 ÷ 52	44 ÷ 52

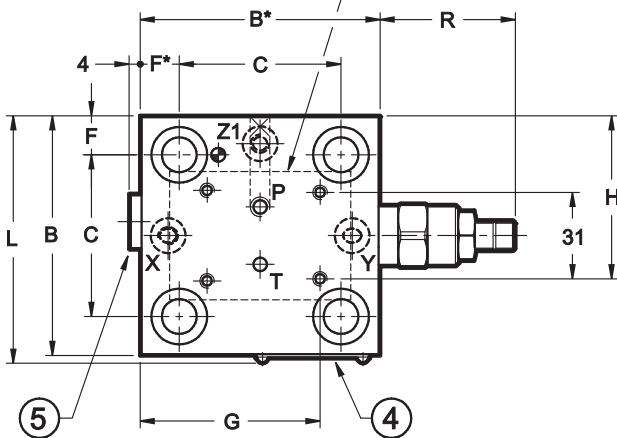
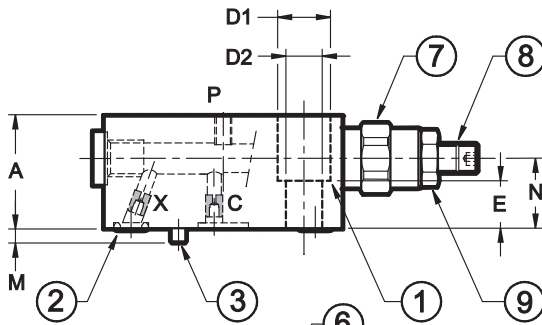

Mass [Kg]	1,36	2,46	4,16	7,40	10,50	17,5
-----------	------	------	------	------	-------	------

#### DP\* restrictors

	M5x6	M6x8			M8x8
X	Ø1,2	Ø1,2	Ø1,2	Ø2,0	Ø2,0
C	Ø0,7	Ø0,7	Ø1,5	Ø1,2	Ø1,5

#### DPE\* restrictors

	M5x6	M6x8	M6x8	M6x8	M6x8
X	Ø0,8	Ø0,7	Ø1	Ø1	Ø1
C	Ø0,6	Ø0,6	Ø0,8	Ø0,8	Ø0,8
Z1	Ø6	Ø6	Ø6	Ø6	Ø6

1	N. 4 fastening bolts ( <b>NOTE</b> ): 16 = M8x30    25 = M12x35 32 = M16x45    40 = M20x50 40 = M20x60    63 = M30x80
2	90 Shore sealing rings : 16 = n° 3 OR type 2025 (6.07x1.78) 25 and 32 = n° 3 OR type 2037 (9.25x1.78) 40 and 50 = n° 3 OR type 2050 (12.42x1.78) 63 = n° 3 OR type 2056 (14.00x1.78)
3	Locating pin:    16 = Ø3x10 25, 32 and 40 = Ø5x14 50 and 63 = Ø6x14
4	Identification label

5	Plug X: 1/4" BSP
6	Mounting surface ISO 4401-03 (CETOP 4.2-4-03-350)
7	Pressure control valve
8	Countersunk hex adjustment screw. Clockwise rotation to increase pressure 16, 25 and 32 = spanner 5 40, 50 and 63 = spanner 6
9	Locking nut: 16, 25 and 32 = spanner 17 40, 50 and 63 = spanner 19

**NOTE:** Fastening bolts class 12.9 UNI 5931 are recommended for the installation of the cover (to be ordered separately)

## 10 - MONITORED LOGIC ELEMENTS

Monitored logic elements are made of a directional function cartridge valve and a cover with built-in inductive proximity sensor. The PNP type sensor with closed contact states the condition of A↔B intercepted flow.

### 10.1 - Identification code of monitored logic elements

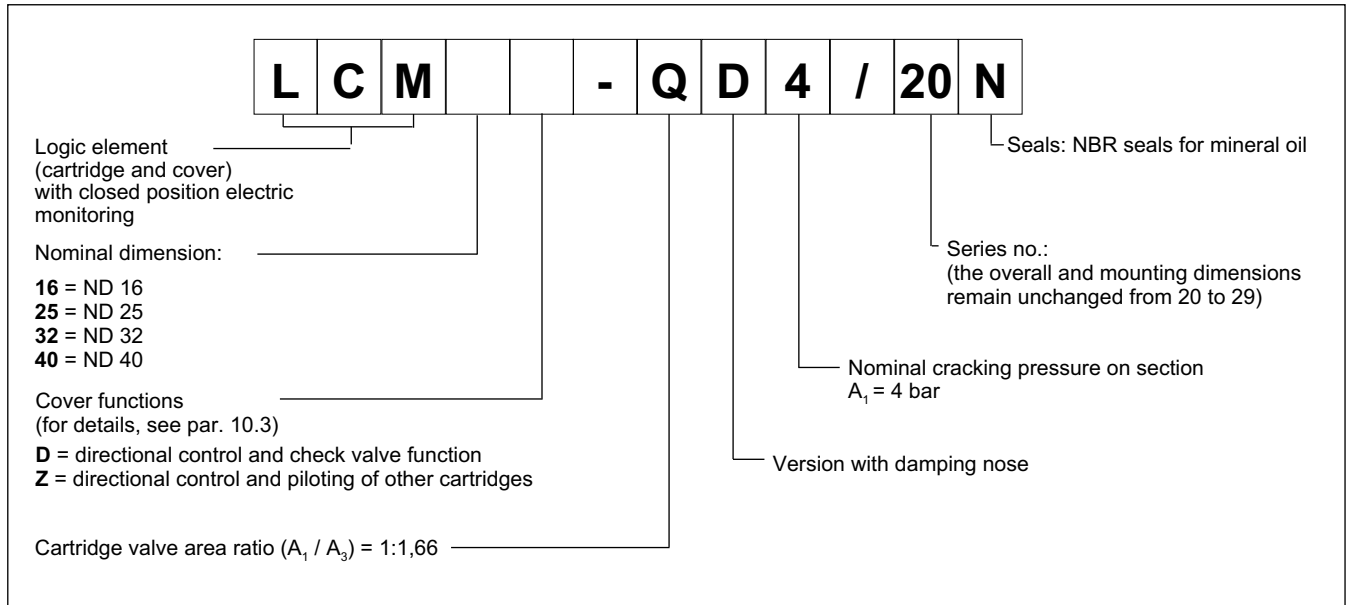

### 10.2 - Characteristic Curves (values obtained with viscosity 36 cSt at 50°C)

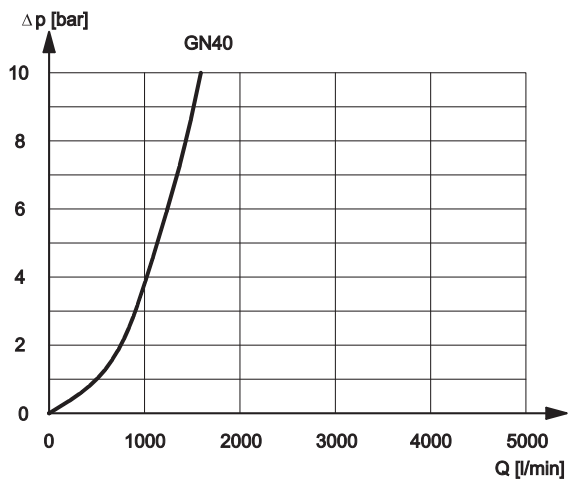
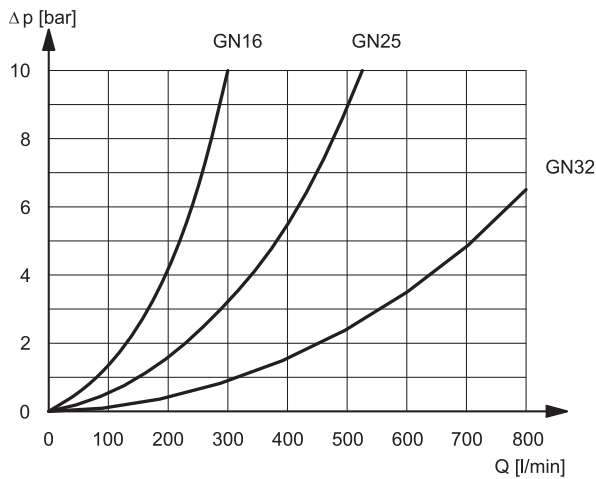

**10.3 - Functional diagram of cover D for directional control and check valve function**

Functional diagram	Description
	<p>Piloting of cartridge valve by means of solenoid valve type DS3-TA (to be ordered separately - see catalogue 41 150)</p> <ul style="list-style-type: none"> <li>- solenoid valve OFF = A → B intercepted flow</li> <li>- solenoid valve ON = A ↔ B free flow</li> </ul>
	<p>Piloting of cartridge valve by means of connection plate code 1950751 to be ordered separately.</p>

**10.4 - Functional diagrams for cover Z for directional control and piloting of other cartridges**

Functional diagram	Description
	<p>Piloting of cartridge valve by means of solenoid poppet valve type <b>DT03-3A</b> (to be ordered separately - see catalogue 42 200). ISO 4401-03 manifold type <b>DN6</b> (cod.0294329) that allows to intercept the flow from two lines, obtaining a tight or the free flow.</p> <ul style="list-style-type: none"> <li>- solenoid valve OFF = sealing tight - A ↔ B locked flow</li> <li>- solenoid valve ON = flow A ↔ B free flow</li> </ul>
	<p>Piloting of cartridge valve by means of connection plate code 1950751 to be ordered separately.</p>

## 10.4 - OVERALL AND MOUNTING DIMENSIONS OF MONITORED LOGIC ELEMENTS

dimensions in mm

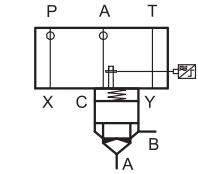

LCM16D-QD4  
LCM25D-QD4  
LCM32D-QD4  
LCM40D-QD4

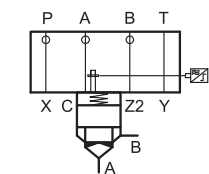
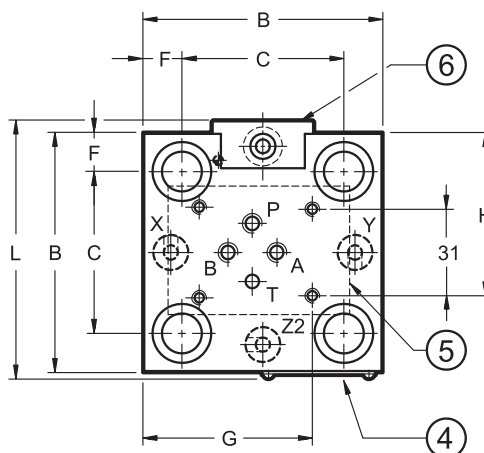
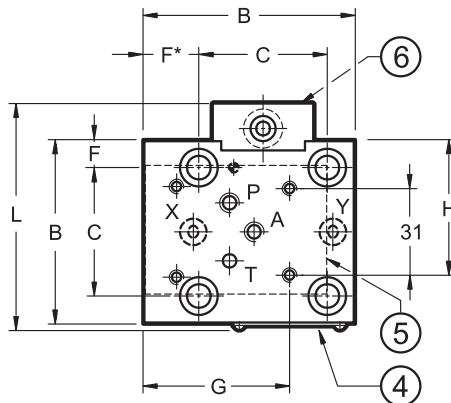
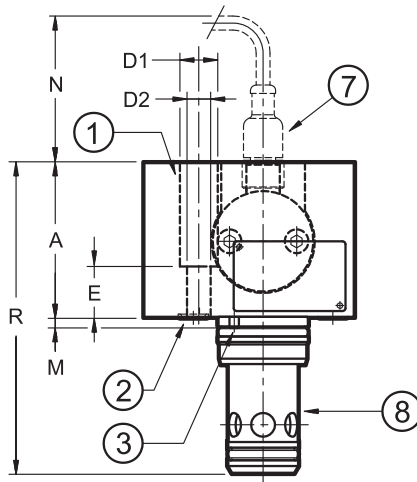

LCM25Z-QD4  
LCM32Z-QD4  
LCM40Z-QD4

	NOMINAL SIZE			
	16	25	32	40
A	55	60	70	75
B	78,5	85	100	125
C	46	58	70	85
D1	13,5	19	25	31
D2	8,5	13	17	21
E	18	17	22	30
F*	19,5	13,5	15	20
F	9,5	13,5	15	20
G	52	60,2	67,7	80,2
H	48	58	65,5	105
L	81	92	102,5	127,5
M	4	5	5	5
N	70	70	65	60
R	111	132	155	180

ports ready for restrictors M6x8.5	P, A B (on cover Z only)			
Mass [Kg]	2,1	3,3	5,3	9,5

1	N. 4 fastening bolts ( <b>NOTE</b> ): <b>16</b> = M8x30 <b>32</b> = M16x45 <b>25</b> = M12x35 <b>40</b> = M20x60
2	n° 3 sealing rings 90 Shore : <b>16</b> = OR type 2025 (6.07x1.78) (on version D there are 2 OR only) <b>25</b> and <b>32</b> = OR type 2037 (9.25x1.78) <b>40</b> = OR type 2050 (12.42x1.78)
3	Locating pin: <b>16</b> = Ø3x10 <b>25, 32</b> and <b>40</b> = Ø5x14
4	Identification label
5	Mounting surface ISO 4401-03 (CETOP 4.2-4-03-350)
6	Proximity sensor
7	Connector for proximity sensor (to be ordered separately see par. 10.6)
8	Cartridge valve always supplied with the cover

**NOTE1:** Fastening bolts class 12.9 UNI 5931 are recommended for cover installation (to be ordered separately).

**NOTE2:** for cartridge valve seat dimensions see par. 5

## 10.5 - Technical characteristics of proximity sensor and relevant connector

### PROXIMITY SENSOR

#### PNP TYPE

Rated voltage	V DC	24
Power supply voltage range	V DC	10 ÷ 30
Absorbed current	mA	200
Output	normally open contact	
Electric protection	polarity inversion short circuit overvoltage	
Electric connection	with connector	
Max operating pressure	bar	350
Operating temperature range	°C	-25 / +80
Class of protection according to CEI EN 60529 standards (atmospheric agents)		IP68
Spool position LED ( <b>NOTE</b> )		NO

**NOTE:** The led is placed in the connector and its light is YELLOW.

### ELECTRIC CONNECTOR (to be ordered separately)

code: ECM3S / M12L / 10

Connector: pre-wired connector M12 - IP68  
cable: with 3 conductors 0.34 mm<sup>2</sup> - length 5 mt - cable material: polyurethane resin (oil resistant)

#### LEDS:

GREEN LED: show the presence of power supply voltage to the connector. If the LED is off, the connector is not supplied.

YELLOW LED: show the valve condition:

- valve at rest      yellow LED on - green LED on
- switched valve    yellow LED off - green LED off

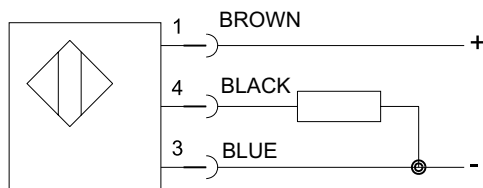

valve closed = closed contact (A↔B intercepted flow)  
valve open = open contact (A↔B free flow)