

# ZDE3

## DIRECT OPERATED PRESSURE REDUCING VALVE WITH ELECTRIC PROPORTIONAL CONTROL

SERIES 30

**SUBPLATE MOUNTING**  
**ISO 4401-03 (CETOP 03)**

**p** max 100 bar  
**Q** max 15 l/min

### MOUNTING INTERFACE

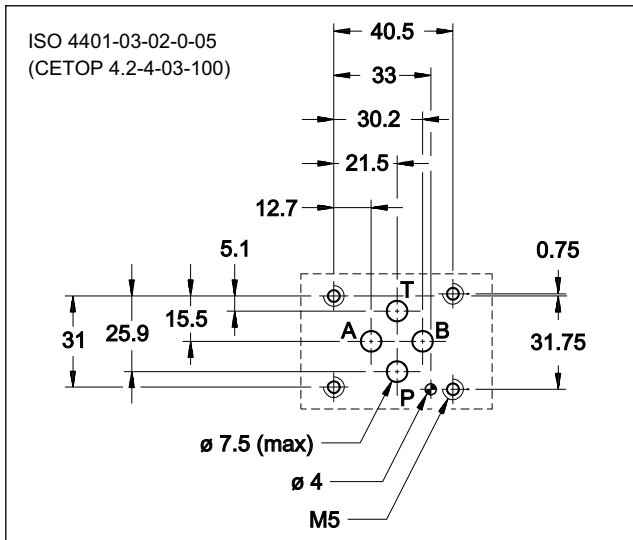

### OPERATING PRINCIPLE

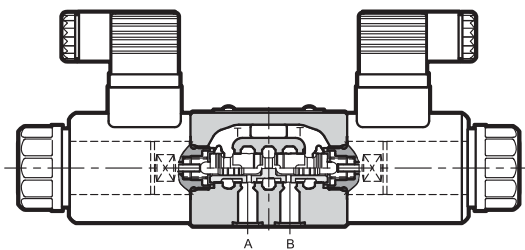

- ZDE3 valves are direct operated pressure reducing valves with electric proportional control, with mounting interface in compliance with ISO 4401 (CETOP RP121H) standards.
- The valves are used to reduce pressure in the secondary circuit branches thus ensuring stability of controlled pressure in the event of variations of the flow rate through the valve.
- The valve can be controlled directly by a current control supply unit or by means of the relative electronic control units to exploit valve performance to the full (see par. 10).

### PERFORMANCES

(obtained with mineral oil with viscosity of 36 cSt at 50°C and electronic control cards)

Operating pressure range:	bar	30 + 100
Pressure allowed on T port (see par. 6)	bar	0 + 30
Controlled pressure	bar	23
Minimum controlled pressure	see $\Delta p$ -Q diagram	
Maximum flow	l/min	15
Step response	see paragraph 5	
Hysteresis (with PWM 200 Hz)	% of p nom	< 4%
Repeatability	% of p nom	< $\pm 1\%$
Electrical characteristic	see paragraph 4	
Ambient temperature range	°C	-20 / +50
Fluid temperature range	°C	-20 / +80
Fluid viscosity range	cSt	10 + 400
Fluid contamination degree	According to ISO 4406:1999 class 18/16/13	
Recommended viscosity	cSt	25
Mass: single solenoid valve	kg	1,6
double solenoid valve		2

### HYDRAULIC SYMBOLS

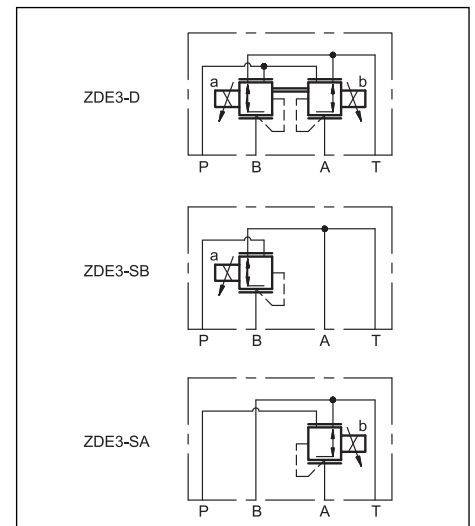

### 1 - IDENTIFICATION CODE

	<b>Z</b>	<b>D</b>	<b>E</b>	<b>3</b>	<b>-</b>	<b>/</b>	<b>30</b>	<b>-</b>		<b>/</b>	
--	----------	----------	----------	----------	----------	----------	-----------	----------	--	----------	--

Pressure reducing valve: \_\_\_\_\_

Electric proportional control \_\_\_\_\_

Size ISO 4401-03 (CETOP 03) \_\_\_\_\_

Solenoids: \_\_\_\_\_  
**D** = pressure reduction in A and B ports  
**SA** = pressure reduction in A port (solenoid on side B)  
**SB** = pressure reduction in B port (solenoid on side A)

Series No. \_\_\_\_\_  
 (from 30 to 39 sizes and mounting dimensions remain unchanged)

Manual override (see par. 9)

Coil electrical connection: (see paragraph 7)  
**K1** = plug for connector type DIN 43650 (**standard**)  
**K7** = plug for connector type DEUTSCH DT04-2P male  
**K12** = plug for M12 connector K1 coils and DUAL DIN 43560

**D12** = Nominal solenoid voltage 12V DC  
**D24** = Nominal solenoid voltage 24V DC

Seals:  
**N** = NBR seals for mineral oil (**standard**)  
**V** = FPM seals for special fluids

### 2 - CHARACTERISTIC CURVES (obtained with ZDE3-D/30N-D24K1 and oil with viscosity 36 cSt at 50°C)

**PRESSURE CONTROL  $p=f(I)$**

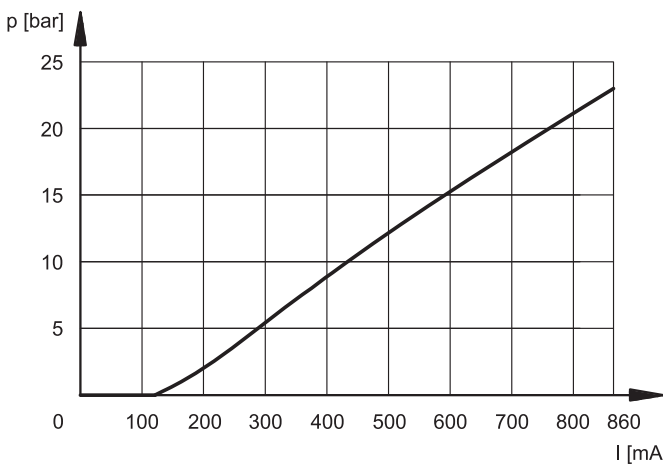

SA and SB versions pressure regulation is less than 0.5 bar.

**PRESSURE VARIATION  $p=f(Q)$**

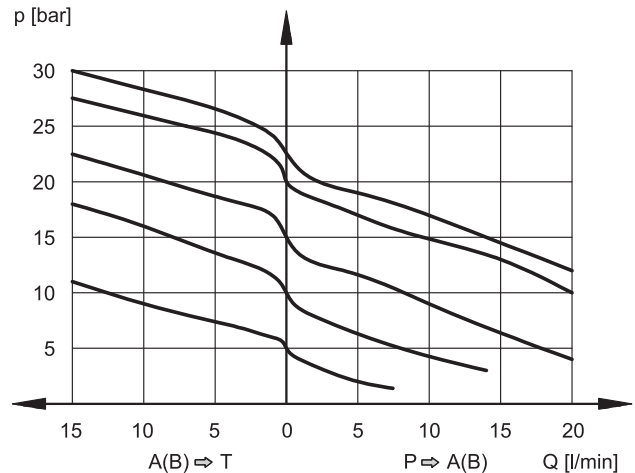

The curves have been obtained with inlet pressure 100 bar.

**PRESSURE DROP  $\Delta p = f(Q)$**

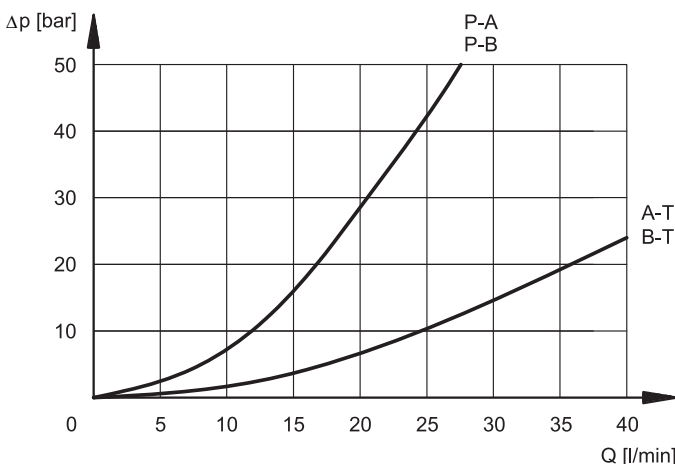

### 3 - HYDRAULIC FLUIDS

Use mineral oil-based hydraulic fluids HL or HM type, according to ISO 6743-4. For these fluids, use NBR seals. For fluids HFDR type (phosphate esters) use FPM seals (code V). For the use of other fluid types such as HFA, HFB, HFC, please consult our technical department.

Using fluids at temperatures higher than 80 °C causes a faster degradation of the fluid and of the seals characteristics. The fluid must be preserved in its physical and chemical characteristics.

### 4 - ELECTRICAL CHARACTERISTICS

#### Proportional solenoid

The proportional solenoid comprises two parts: tube and coil.

The tube, screwed to the valve body, contains the armature which is designed to maintain friction to a minimum thereby reducing hysteresis.

The coil is mounted on the tube secured by means of a lock nut and can be rotated through 360° depending on installation clearances.

<b>NOMINAL VOLTAGE</b>	V DC	<b>12</b>	<b>24</b>
<b>RESISTANCE (at 20°C)</b>	Ω	K1 COIL 3.66	K7 COIL 17.6
		4	19
<b>MAXIMUM CURRENT</b>	A	1.88	0.86
<b>DUTY CYCLE</b>		100%	
<b>PWM FREQUENCY</b>	Hz	200	100
<b>ELECTROMAGNETIC COMPATIBILITY (EMC)</b>	According to 2004/108/CE		
<b>PROTECTION FROM:</b> Atmospheric agents (CEI EN 60529)	IP 65		
<b>CLASS OF PROTECTION :</b> Coil insulation (VDE 0580) Impregnation:	class H class F		

### 5 - STEP RESPONSE

(with mineral oil with viscosity of 36 cSt at 50°C and with the relative electronic control unit)

Step response is the time taken for the valve to reach 90% of the set pressure value following a step change of reference signal.

The table illustrates typical step response times measured with input flow rate of Q = 5 l/min and p = 50 bar.

<b>REFERENCE SIGNAL STEP</b>	0 → 100%	100 → 0%
Step response [ms]	30	30

### 6 - INSTALLATION

The ZDE3\* valves can be installed in any position without impairing correct operation.

Ensure that there is no air in the hydraulic circuit.

Valves are fixed by means of screws or tie rods on a flat surface with planarity and roughness equal to or better than those indicated in the relative symbols. If minimum values are not observed fluid can easily leak between the valve and support surface.

Connect the valve T port directly to the tank. Add any backpressure value detected in the T line to the reduced pressure value. Maximum admissible backpressure in the T line, under operational conditions, is 30 bar.

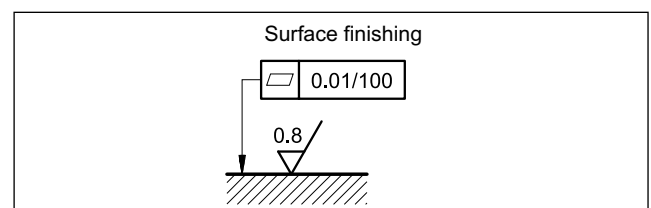

## 7 - ELECTRIC CONNECTIONS

The valve is supplied with connection K1. Alternatively, there are connections K7 and K12 DUAL DIN. DUAL DIN connector allows you to power two solenoids with connection K1 with a single cable with socket M12.

connection for DIN 43650 connector type  
code **K1 (standard)**

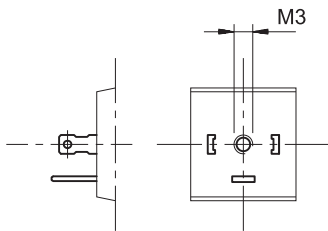

connection for DEUTSCH DT04-2P male  
connector type  
code **K7**

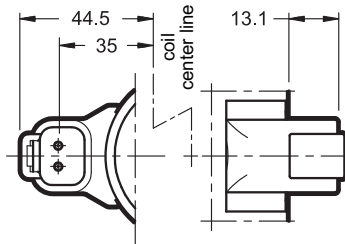

connection for DUAL DIN 43650 connector type  
code **K12**

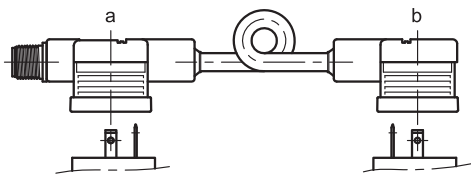

CONNECTOR M12x1 CONNECTION SCHEME

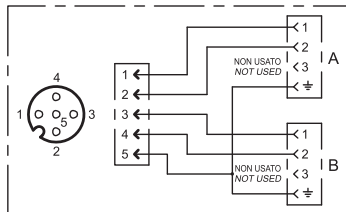

## 8 - OVERALL AND MOUNTING DIMENSIONS

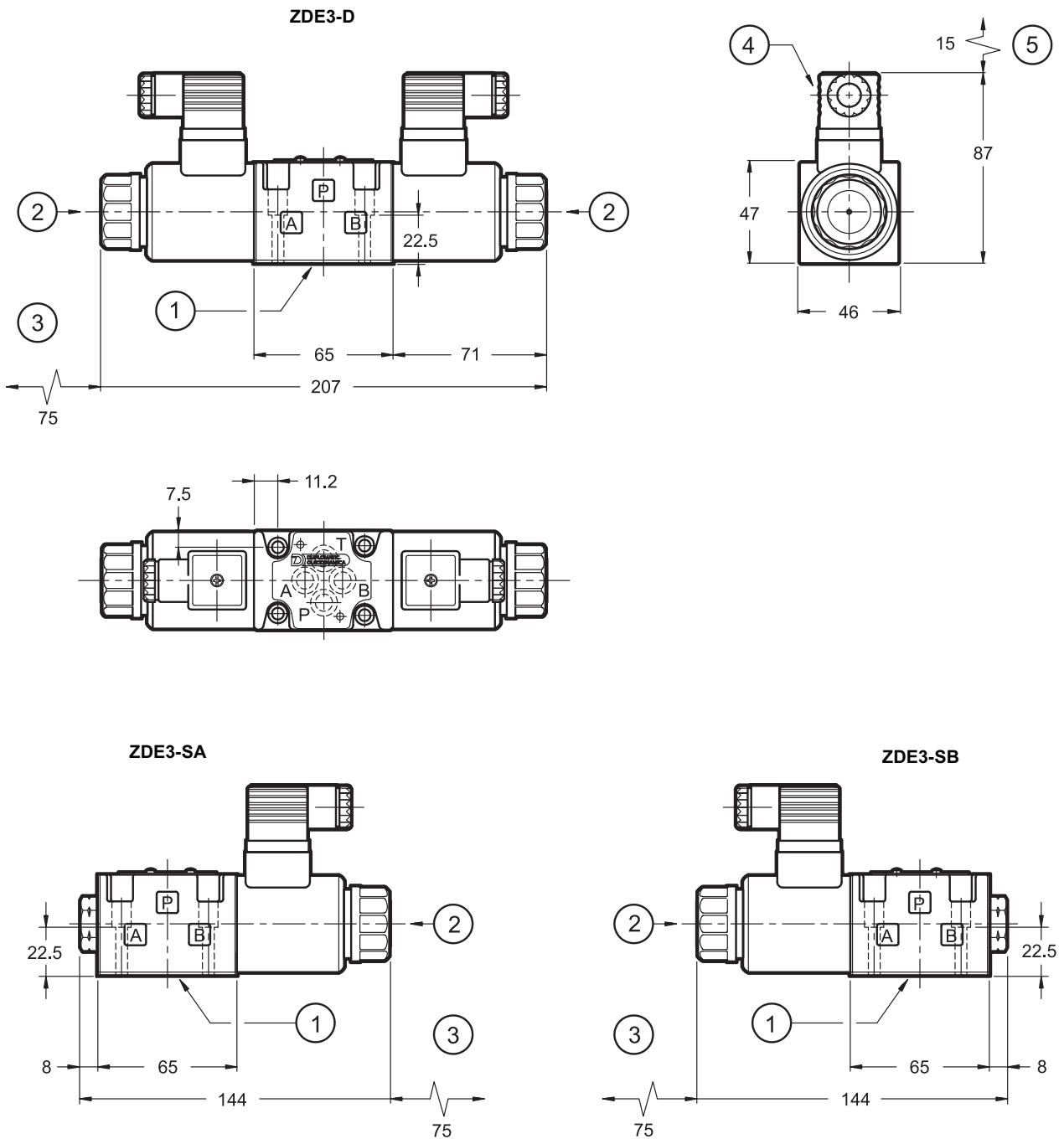

dimensions in mm

Fastening bolts: n° 4 bolts A8.8 M5x30  
Torque: 5 Nm

1	Mounting surface with sealing rings: 4 OR type 2037 - 90 shore (9.25x1.78)
2	Locking ring with boot protected manual override
3	Coil removal space
4	DIN 43650 electrical connector
5	Connector removal space

### 9 - MANUAL OVERRIDE

The standard valve has solenoids whose pin for the manual operation is integrated in the tube. The operation of this control must be executed with a suitable tool, minding not to damage the sliding surface.

Two different manual override version are available upon request:

- **CM** version, manual override belt protected
- **CS** version, with metal ring nut provided with a M4 screw and a blocking locknut to allow the continuous mechanical operations.



**CAUTION!** The manual override use doesn't allow any proportional regulation; indeed using this kind of override, the main stage spool will open completely and the whole inlet pressure will pass through A or B line.

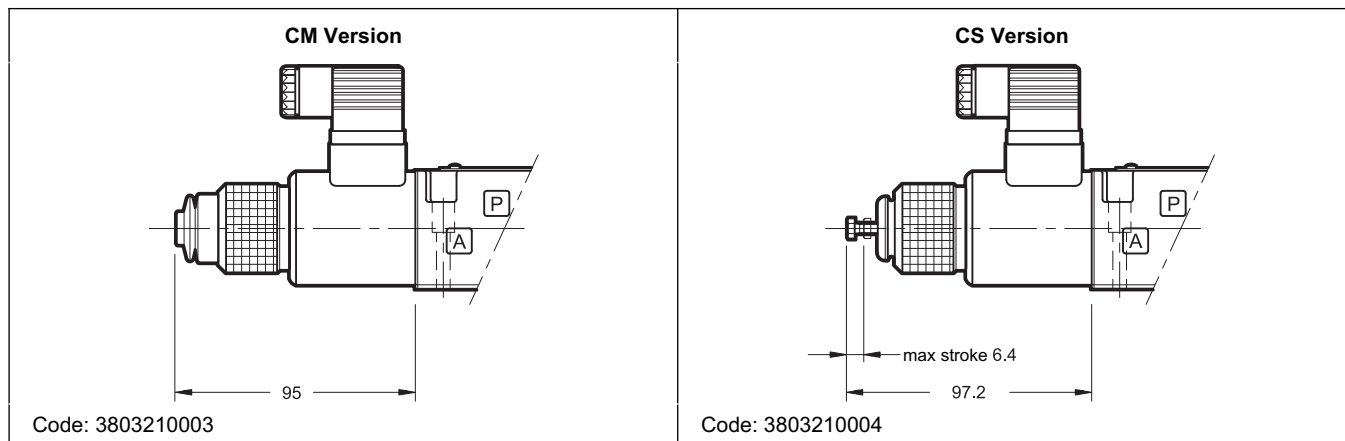

### 10 - ELECTRONIC CONTROL UNITS

#### ZDE3-SA\* ZDE3-SB\*

<b>EDC-111</b>	for solenoid 24V DC	plug version	see cat.89 120
<b>EDC-142</b>	for solenoid 12V DC		
<b>EDM-M111</b>	for solenoid 24V DC	DIN EN 50022 rail mounting	see cat. 89 250
<b>EDM-M142</b>	for solenoid 12V DC		

#### ZDE3-D\*

<b>EDM-M211</b>	for solenoid 24V DC	rail mounting DIN EN 50022	see cat. 89 250
<b>EDM-M242</b>	for solenoid 12V DC		

### 11 - SUBPLATES (See catalogue 51 000)

Type PMMD-AI3G with rear ports
Type PMMD-AL3G with side ports
P, T, A, B port threading: 3/8" BSP

**DUPLOMATIC OLEODINAMICA**

**DUPLOMATIC OLEODINAMICA S.p.A.**  
 20015 PARABIAGO (MI) • Via M. Re Depaolini 24  
 Tel. +39 0331.895.111  
 Fax +39 0331.895.339  
 www.diplomatic.com • e-mail: sales.exp@diplomatic.com