



M63

PRESSURE GAUGE

SERIES 10

according to EN 837-1

TECHNICAL CHARACTERISTICS

Nominal diameter	mm	63		
Nominal pressure	bar	0 ÷ 6	0 ÷ 10	0 ÷ 16
		0 ÷ 25	0 ÷ 60	0 ÷ 100
		0 ÷ 160	0 ÷ 250	0 ÷ 400
Static pressure	3/4 of the end scale value			
Dynamic pressure	2/3 of the end scale value			
Limit pressure	end scale value for short period			
Precision class according to EN 837-1/6	1.6			
Thermal drift	± 0,4% / 10K in the measure range			
Protection class according to EN 60529 - IEC 529	IP 65			
Ports according to EN 837-1/6	1/4" BSP			
Ports material	copper alloy			
Sensible element:	0 ÷ 6, 0 ÷ 10, 0 ÷ 16, 0 ÷ 25, 0 ÷ 60.		copper alloy, type-C, braze welding spring	
	0 ÷ 100, 0 ÷ 160, 0 ÷ 250, 0 ÷ 400.		copper alloy, helical, braze welding spring	
Movements	copper alloy			
Dial	white plastic with lock pins in black plastic			
Case	stainless steel with natural finishing, and OR between case and shank			
Display	transparent plastic			
Filling liquid	glycerin 85% + distilled water 15%			
CE Marking	in compliance with 97/23/CE of 29.05.97 art. 3 par. 3			
Working temperature range	°C	-20 / +60		
Mass	kg	0,24		

DESCRIPTION

- The pressure gauges M63 are pressure indicators used on hydraulic systems.
- They guarantee a correct pressure measurement also with pulsations and vibrations.
- They are available in 9 different pressure scales and with 2 connection types for mounting with radial port or rear port with flange connector.
- The case is made of stainless steel and the connection is made of copper alloy.
- The filling in liquid is made of 85% glycerin and 15% distilled water.
- As they are realised in compliance with 97/23/CE of the 29-05-97 art. 3 par. 3, only the ones with the end scale of 250 and 400 bar have the marking CE on the dial.
- The construction and the realisation have been done according to EN 837-1.

HYDRAULIC SYMBOL

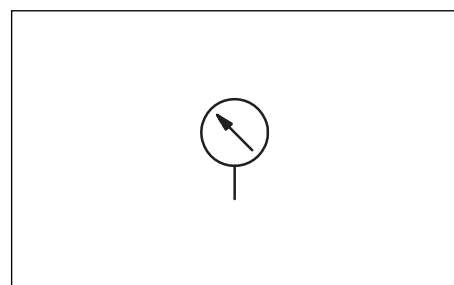



1 - IDENTIFICATION CODE

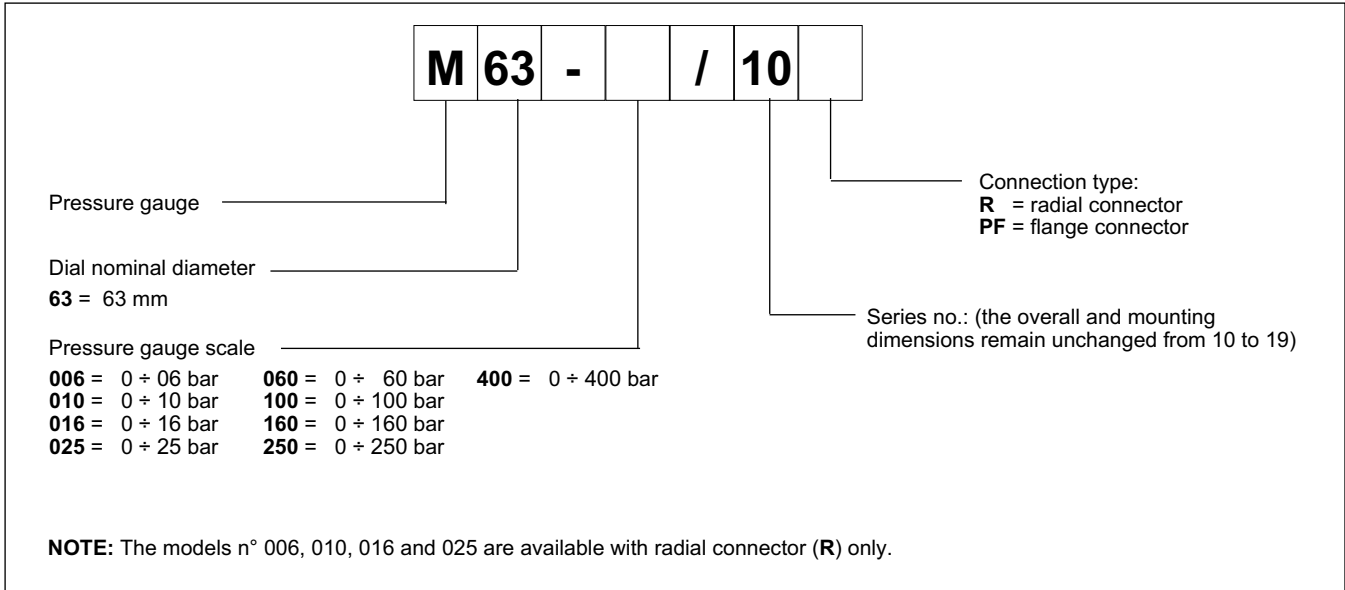

2 - OVERALL AND MOUNTING DIMENSIONS

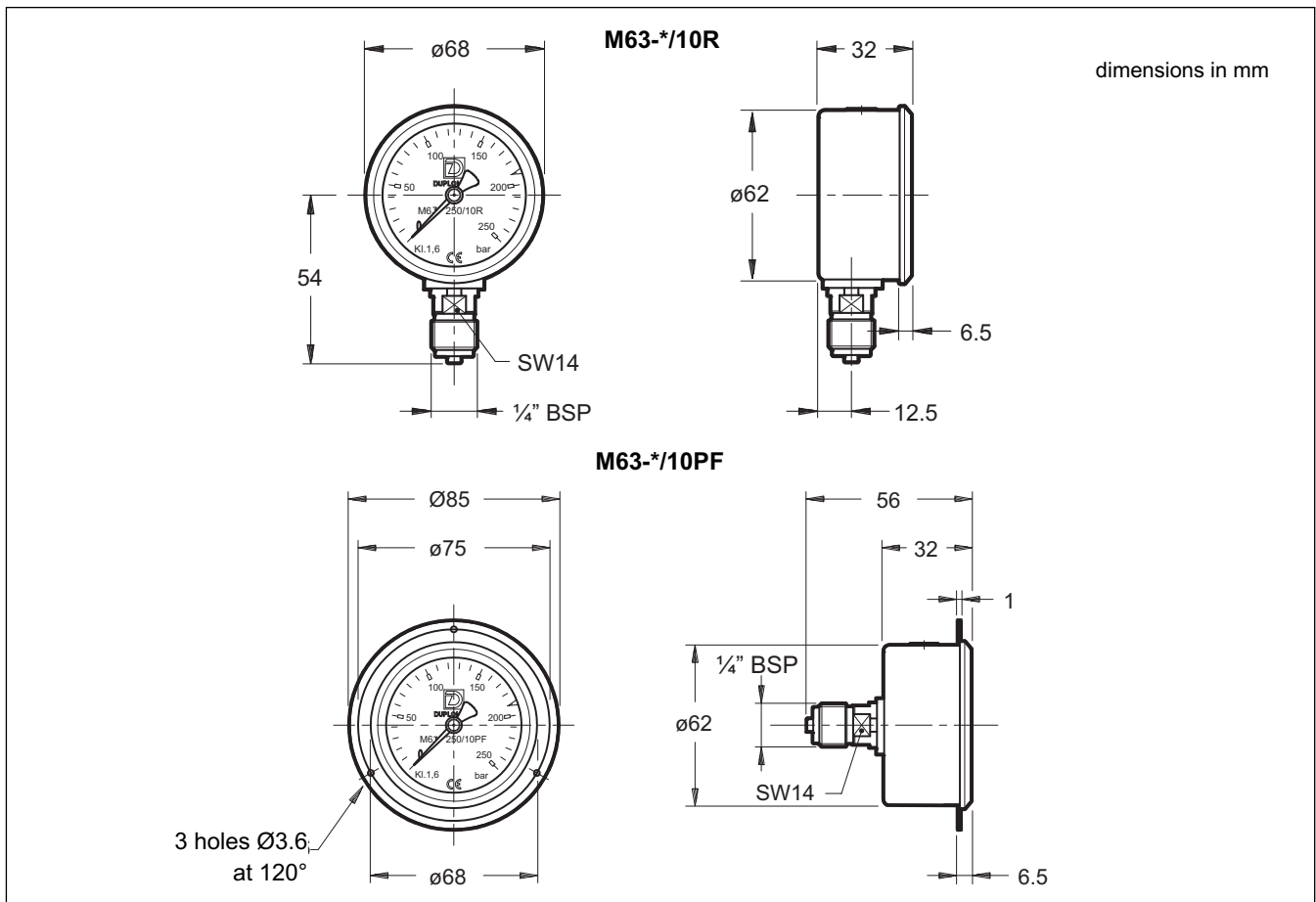

DIPLOMATICO OLEODINAMICA S.p.A.
 20015 PARABIAGO (MI) • Via M. Re Depaolini 24
 Tel. +39 0331.895.111
 Fax +39 0331.895.339
 www.diplomatic.com • e-mail: sales.exp@diplomatic.com