

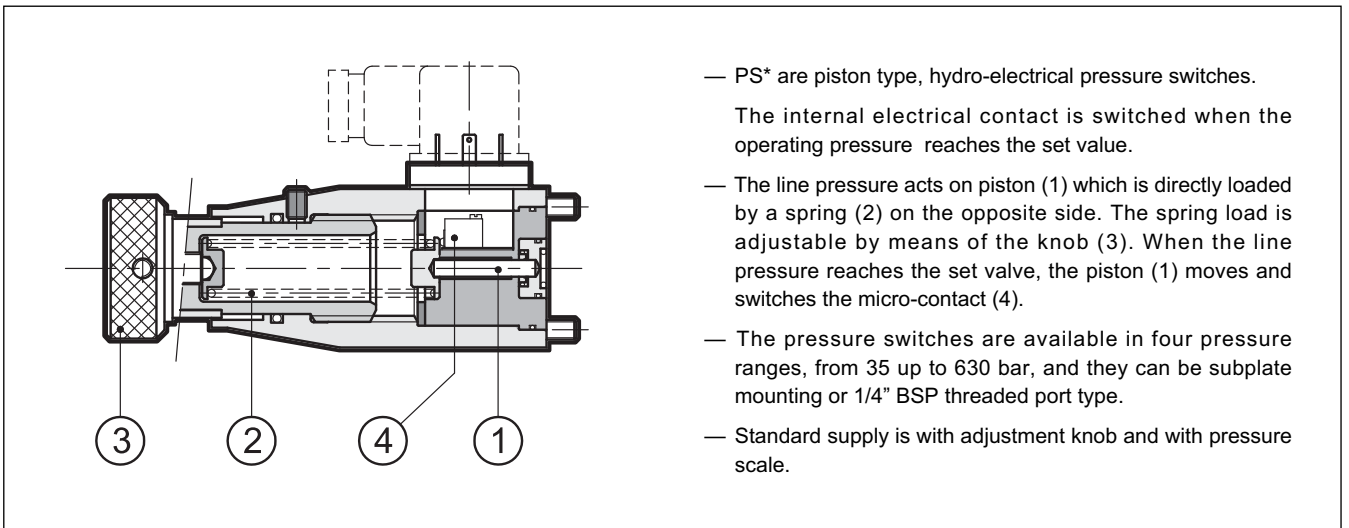

PS*
PISTON TYPE
PRESSURE SWITCH
SERIES 21

p max **650** bar
max adjustable **p** **35 - 140 - 350 - 630** bar

OPERATING PRINCIPLE



TECHNICAL CHARACTERISTICS

PRESSURE SWITCH		PS*2	PS*4	PS*6	PS*8
Pressure adjustment range	bar	3 ÷ 35	6 ÷ 140	10 ÷ 350	20 ÷ 630
Max operating pressure	bar	350	350	650	650
Hysteresis	see par. 5				
Repeatability	< ± 1 % of set pressure				
Electrical characteristics	see par. 3				
Ambient temperature range	°C	-20 / +50			
Fluid temperature range	°C	-20 / +80			
Fluid viscosity range	cSt	10 ÷ 400			
Recommended viscosity	cSt	25			
Fluid contamination degree	according to ISO 4406:1999 class 20/18/15				
Mass	kg	0,67			

SYMBOLS

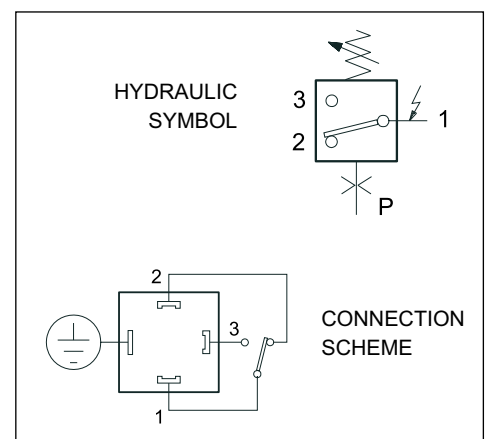

1 - IDENTIFICATION CODE

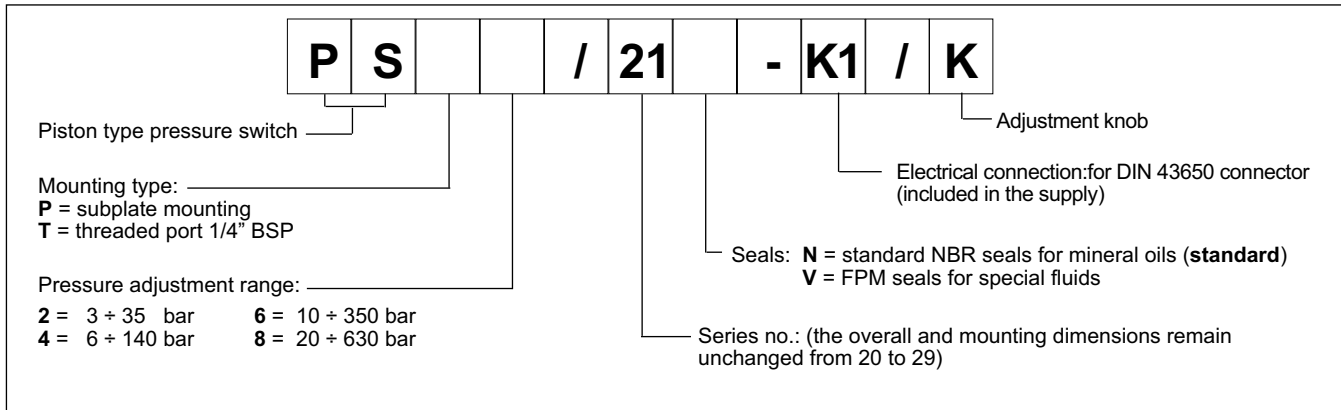

2 - HYDRAULIC FLUIDS

Use mineral oil-based hydraulic fluids HL or HM type, according to ISO 6743-4. For these fluids, use NBR seals (code N).
 For fluids HFDR type (phosphate esters) use FPM seals (code V).
 For the use of other fluid types such as HFA, HFB, HFC, please consult our technical department.
 Using fluids at temperatures higher than 80 °C causes a faster degradation of the fluid and of the seals characteristics.
 The fluid must be preserved in its physical and chemical characteristics.

3 - ELECTRICAL CHARACTERISTICS

		AC		DC	
Power supply	V	125	250	30	250
Max load on contacts					
- resistive	A	7	5	5	0,2
- inductive		4	2	3	0,02
Electrical insulation (according to CEI EN 60204)		> 1 M Ω at 500 Vdc			
Max switching rate	switches/min	120			
MTBF mechanical parts	switches	10.000.000			
MTBF electrical contacts	switches	2.000.000			
Protection class (according to CEI EN 60529)		IP 65			

4 - INSTALLATION

The pressure switches can be installed in any position without impairing its correct operation. Ensure that there is no air in the hydraulic circuit.

The subplate mounting pressure switch PSP type is fixed by means of screws on a flat surface with planarity and roughness values equal to or better than those indicated in the relative symbols. If the minimum values are not observed, the fluid can easily leak between the valve and the mounting surface.

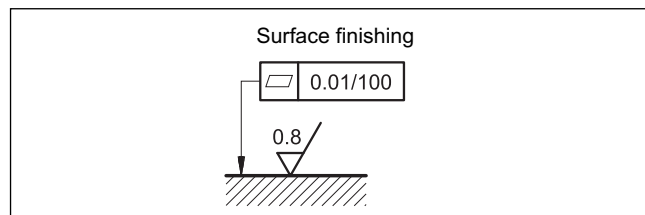

5 - HYSTERESIS CHARACTERISTICS (values measured with viscosity of 36 cSt at 50°C)

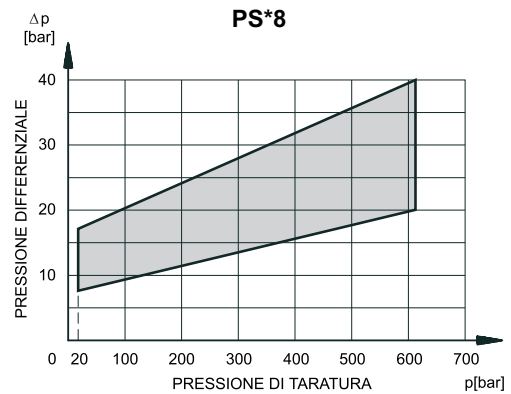
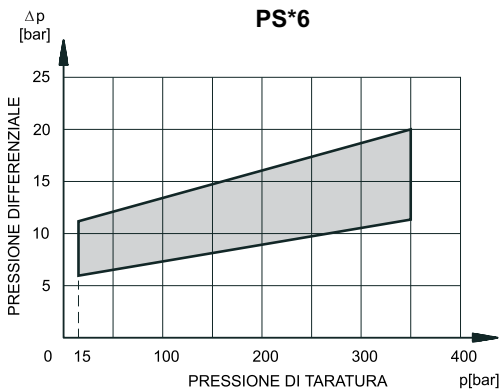
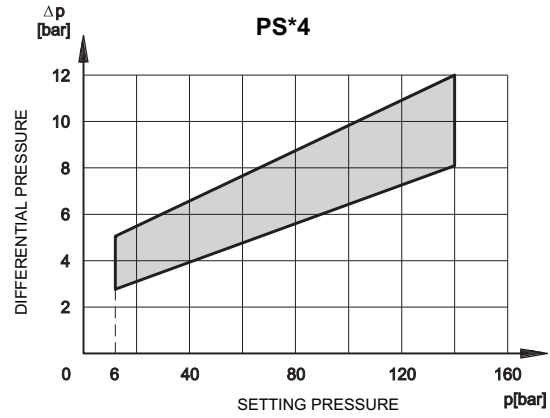
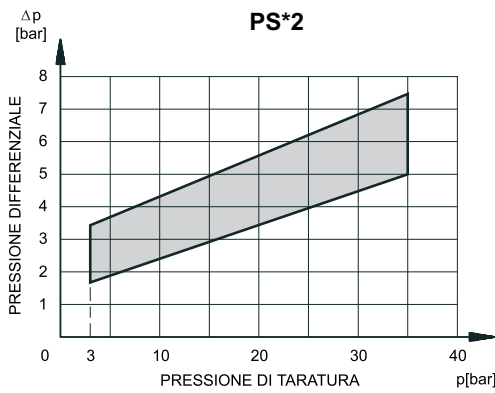

6 - SUBPLATES FOR STACK MOUNTING

The PSP pressure switches can be stack mounted by means of ISO 4401-03 (CETOP 03 subplates), code 1950611 and 1950621. The subplate code 1950611 permits the connection between the pressure switch and A and/or B ports, depending on where the bolt (1) is installed. The subplate code 1950621 permits the connection between the pressure switch and the P port.

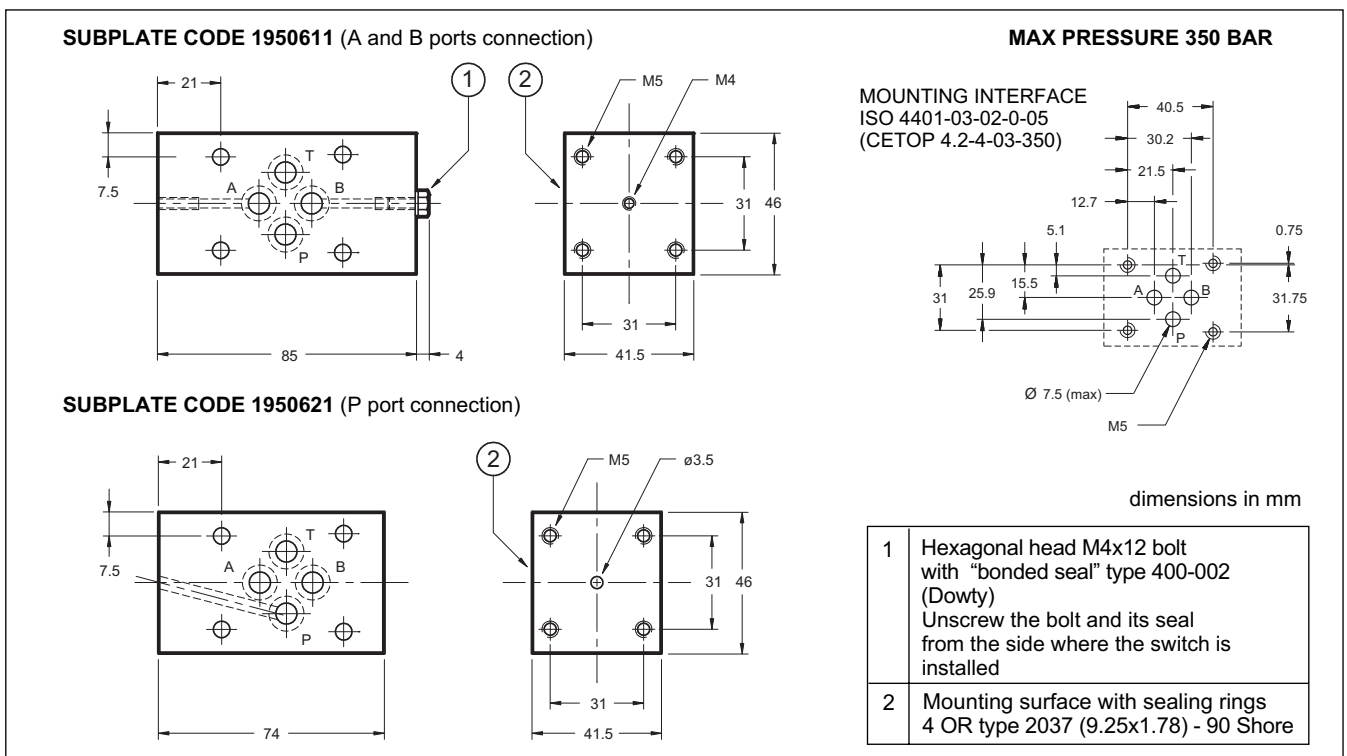

7 - OVERALL AND MOUNTING DIMENSIONS

PSP

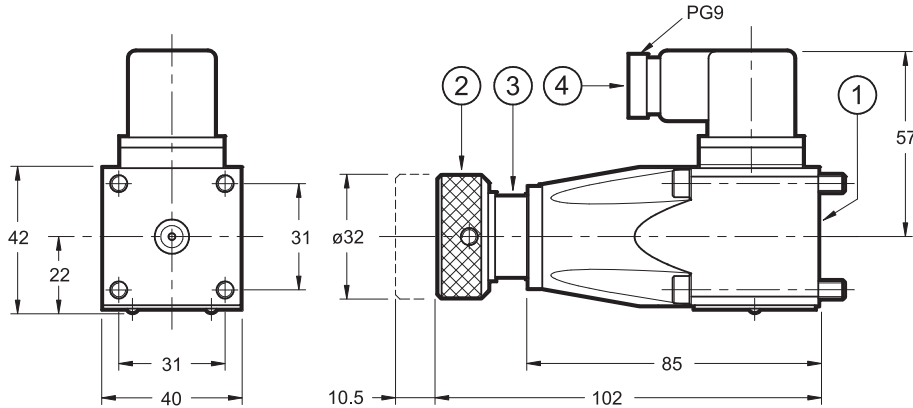

PST

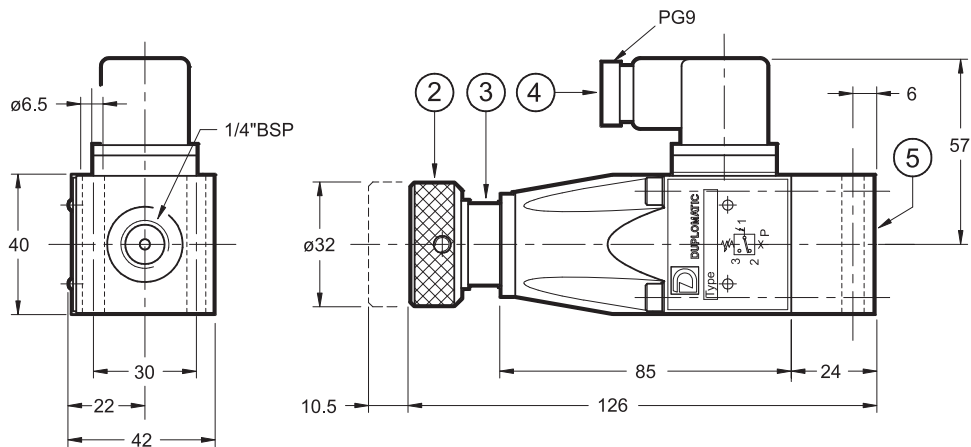

MOUNTING INTERFACE (PSP version)

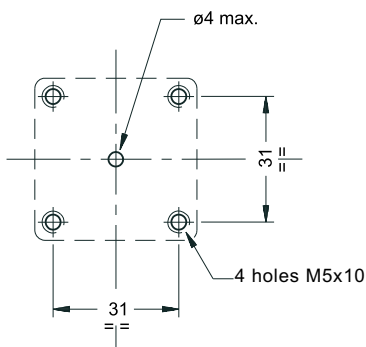

dimensions in mm

fastening bolts (PSP version)
4 bolts M5x45 - 12.9 resistance class (included in the supply)
Tightening torque: 8 Nm

1	Mounting surface with sealing rings: 1 OR type 2025 (6.07x1.78) - 90 shore (PSP version)
2	Adjustment knob Clockwise rotation to increase pressure
3	Graduated scale with indication of setting pressure in [bar]
4	DIN 43650 electrical connector 3 poles + ground supplied with pressure switch
5	Interface plate for pipe connection: - 1/4" BSP threaded female connection - 2 clearance holes for possible fixing by means of bolts M5x50 NOTE: the interface plate is already installed on the PST type pressure switch only.